

Anchoring & Fixing
Threaded inserts

Leviat[®]
A CRH COMPANY

Halfen Demu Fixing anchor

Technical Product Information



Imagine. Model. Make.

Leviat®

A CRH COMPANY

We imagine, model and make engineered products and innovative construction solutions that help turn architectural visions into reality and enable our construction partners to build better, safer, stronger and faster.

Leviat is a world leader in connecting, fixing, lifting and anchoring technology.

From the build of new schools, hospitals, homes and infrastructure, to the repair and maintenance of heritage structures, our engineering skills are making a difference around the world.

We provide technical design assistance at every stage of a project, from initial planning to installation and beyond.

Our technical support services range from simple product selection through to the development of a fully customised project-specific design solution.

Every promise we make locally, has the commitment and dedication of our global team behind it. We employ almost 3,000 people at 60 locations across North America, Europe and Asia-Pacific, providing an agile and responsive service worldwide.

Leviat, a CRH company, is part of the world's leading building materials business.





>3,000
People

60+
Locations

~20
Countries

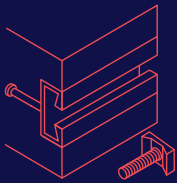

Anchoring & Fixing

Systems for fixing secondary fixtures to concrete, including anchor channels, bolts and inserts; also tension rod systems for roofs and canopies.

- Cast-in Channels, T-Bolts & Accessories
- Threaded Inserts
- Rod Systems
- Attachment Points
- Post Installed Anchor Systems

Other areas of expertise:

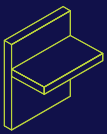

Structural Connections

Systems to form robust, efficient connections, and continuity of concrete reinforcement as necessary, between walls, slabs, columns, beams and balconies, providing structural integrity as well as enhanced thermal and acoustic performance.

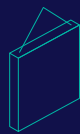

Lifting & Bracing

Systems for the safe and efficient transportation, lifting and temporary bracing of cast concrete elements and tilt-up panels before permanent structural connections are made.



Façade Support & Restraint

Systems for the safe and thermally-efficient fixing of the external building envelope, including brick and natural stone, insulated sandwich panels, curtain walling and suspended concrete façades, and also the repair and strengthening of existing masonry installations.



Formwork & Site Accessories

Non-structural accessories that complement our engineered solutions and help keep your construction environment operating safely and efficiently, including moulds for casting standard and special concrete elements and construction essentials such as reinforcing bar spacers.

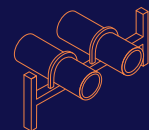

Industrial Technology

Mounting channels, pipe clamps and other versatile framing systems that provide safe fixing in a wide range of industrial applications.

Leviat product ranges:

Ancon | Aschwanden | Connolly | Halfen | Helifix | Isedio | Meadow Burke | Modersohn | Moment | Plaka | Scaldex | Thermomass

Halfen Demu fixing anchor

Features

Halfen Demu Fixing anchors are intended for permanent anchorage in concrete. Different dimensions and variants for corrosion protection offer a wide product range.

- Combination of standard anchor sleeve and bolt anchor with metrical ISO thread
- Diameters from M10 to M20
- For permanent anchoring under predominantly static or quasi static actions
- For reinforced and non-reinforced normal weight concrete from strength class C20/25 to C50/60, (cracked or non-cracked concrete)
- For transmission of tensile loads, shear loads and a combination of both



Product Safety

- Since July 2013 with European Technical Approval (ETA)
- Optimised calculation based on current state of the art technology
- Free design software available
- Dataclip for easy identification

Material and corrosion protection

- Corrosion protection in GV (zinc galvanised) and in stainless steel A4 (A4-50)

YOUR BIM PARTNER: Building Information Modeling

All Halfen products for the precast industry are available as BIM enabled (Building Information Modeling) CAD files. These are suitable for use in a 3D model of your project.

BIM software for planning, realising and building maintenance significantly

simplifies collaboration between architects, clients and contractors. All relevant information for the construction project is available on a single platform.

Connections between building elements can be quickly checked and any

problems solved. All parties involved in the process are able to react appropriately, saving time and costs.



Halfen Demu fixing anchor

Contents

1 Systematic fixing solution	6–12
TWS Hexagon Plate anchor	6
Application examples	8
Advantages	9
Typical applications / Load diagrams	10
Design concept	11
2 General information	13
Material / Corrosion protection	13
3 T-FIXX® Anchors	14–15
General information	14
T-FIXX®	15
4 Bolt anchor	16–21
1988	16
1985	19
1980-P	20
5 Bar anchor	22–30
4010 / 3016 / 3010 / 1988-S	22
4030 / 1558	27
Bending of bar anchors	30
6 Accessories	31–36
Fixing pins, nailing plates, sealing caps, thread adapters	31
Positioning plate	33
7 Installation instructions	34–35
Fixing anchors, accessories	35
8 Fixing components – assembly instruction	36
General information / Determining the required bolt length	36
9 Software	37
Calculation basics / Calculation software	37
Tender text	39
Calculation example	40
10 Contacts	42

Halfen Demu fixing anchor

Halfen TWS Hexagon plate anchor

Halfen TWS Hexagon plate anchor

The Halfen TWS Hexagon plate anchors are used as auxiliary aids when erecting precast elements. For example, temporary anchor points for push-pull props for fixing twin-walls to in-situ concrete floor slabs and foundation slabs. The hexagon plate anchor is suitable for wind loads and other temporary loads.

Application example:
Temporary anchor points for push-pull props for fixing twin-walls to concrete floor slabs.

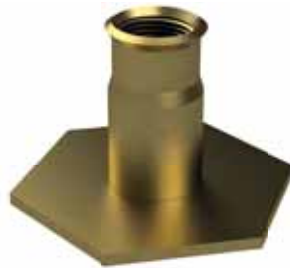

Benefits

- The concrete capacity at design level ($F_{Rd,h}$) was verified and certified by the French CERIB* testing authority
- The capacities were determined in tests using concrete with a strength class of C20/25 and C30/37
- Applicable for thin shell elements with a minimum thickness from 50 mm to 55 mm
- Wide tube openings with metric thread allow easy installation
- Friction welded steel components ensure durability
- New! Magnetic plate available without thread for robot-automated installation
- Three options for combining different magnet plates with the same socket type

*Centre d'Études et de Recherches de l'Industrie du Béton (Concrete Industry Study and Research Centre)

TWS Dimensions

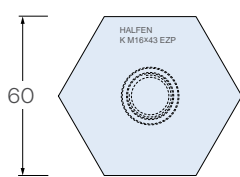

Dimensions [mm]

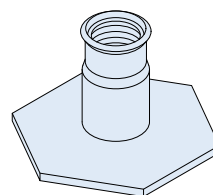
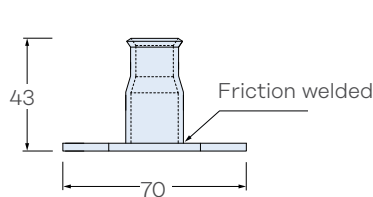

Hexagon plate anchor

Order no.

3000020604

Accessories

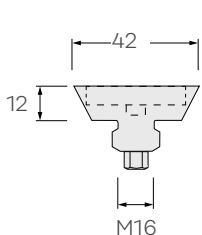

Type: M16/42/12

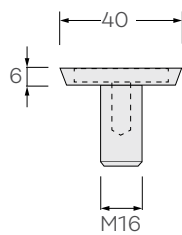

Type: M16/40/6

Dimensions [mm]

Magnetic plate for M16	
Type	Article name Magnetic plates for plate anchor
M16/42/12	M16 - 42 -12
M16/40/6	M16 - 40 - 6 without thread

Halfen Demu fixing anchor

Halfen TWS Hexagon plate anchor

Tested reinforcement layout (HA6):

Plan

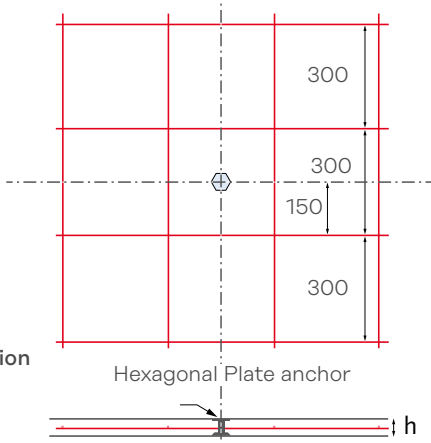

Section

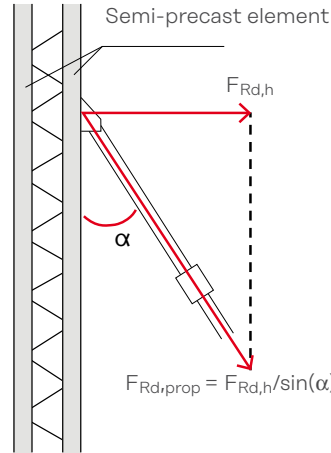

Type M16/42/12:
CERIB Test report no. 022274
Type M16/40/6:
CERIB Test report no. 024926
Type M16/55/5:
CERIB Test report no. 024927

Dimensions [mm]

Excerpt from the CERIB certificate			
Type	M16/42/12	M16/40/6	M16/55/5
$F_{Rd,h}$ ①	9.2 kN ③	9.4 kN ④	7.4 kN ③
Minimum inclination of angle α	30°		
Maximum force $F_{Rd,prop}$ ②	18.4 kN ③	18.8 kN ③	14.8 kN ③
Minimum nominal wall thickness h	55 mm	50 mm	50 mm
Minimum edge distance c_{min}	100 mm		
Minimum axial spacing s_{min}	200 mm		
Concrete compressive strength class	C20/25	C30/37	C20/25
Minimum wall reinforcement	HA6 spaced 30 cm in both directions		
Tightening torque T_{inst}	30 Nm		

- ① The concrete capacity at design level $F_{Rd,h}$, perpendicular to the surface of the wall was calculated with $\gamma = 1.5$ ($F_{Rd,h} = F_{Rk,h}/1.5$) according EN1992-4 assuming concrete cone failure.
- ② The force in the central axis of the prop, $F_{Rd,prop}$, must not exceed the value = $F_{Rd,h}/\sin(30^\circ)$.
- ③ For other concrete compressive strength classes, multiply by the factors 1.10 (C25/30) and 1.22 (C30/37).
- ④ For other concrete compressive strength classes, multiply by the factors 0.82 (C20/25) and 0.90 (C30/37).

Installation instructions

- 1 Attach the magnetic plates to steel formwork

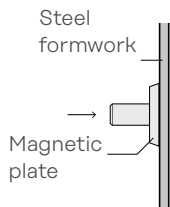

- 2 Assemble the Halfen TWS Hexagon plate anchors onto the magnetic plates

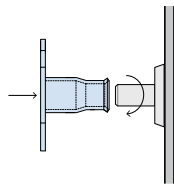

- 3 Install all other required reinforcement

- 4 Pour and compact the concrete

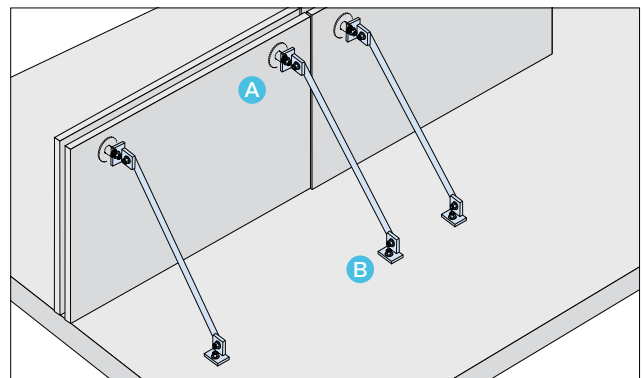

- 5 After the concrete has cured, remove the formwork and the magnetic plates

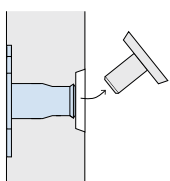

- 6 Install the bracket for the prop. Screw in and tighten the bolt, $T_{inst} \rightarrow$ see table

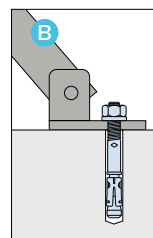
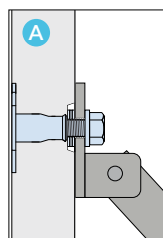
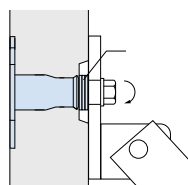

Multi-lingual installation instruction are available at www.halfen.com ► Publications ► Installation instructions.

Halfen Demu fixing anchor

Application examples

Fixing of balcony railings



Fixing and adjusting precast elements



Fixing of solar panels



Installation of fixing anchors



Fixing props to precast elements



Application of precast elements for stadiums



Fixing of seats



Fixing of bridge railings



© Photo: Romijn Beton

Halfen Demu fixing anchor

Advantages









Systematic Fixing Solutions

Demu Fixing anchors with internal thread are intended to be used for permanent anchorages under predominantly static actions or

quasi-static actions in reinforced and unreinforced normal weight concrete from strength class C20/25 to C90/105.

They may be used in cracked or non-cracked concrete for transmission of tensile loads, shear loads or a combination of both.



	T-FIXX®	Bolt anchor	Bar anchor
Loads	Medium load capacity	High load capacity	High load capacity
Application	<ul style="list-style-type: none"> medium loads near edges applications (can also be used high strength concrete) thin elements load capacity of concrete decisive normal strength concrete 	<ul style="list-style-type: none"> high loads does not affect edge and axial spacings high steel strength required application also in high strength concrete 	<ul style="list-style-type: none"> high tension loads (pullout) application also in the edge of thin elements (requires deep embedment depths) high steel strength required up to high strength concrete
Example applications typical use:	<ul style="list-style-type: none"> fixing of railings for balconies, bridges fixing of service equipment installation trays/brackets fixing of stadium seats fixing of steel ladders or stairs connection of precast elements prop-fixing with precast elements windows 	<ul style="list-style-type: none"> fixing of railings for balconies, bridges fixing of service equipment installation trays/brackets fixing of stadium seats fixing of steel ladders or stairs 	<ul style="list-style-type: none"> fixing of railings for balconies, bridges fixing of service equipment installation trays/brackets fixing of stadium seats fixing of steel ladders or stairs
Design concept/ Calculation	 in accordance with EN 1992-4	 in accordance with EN 1992-4	 in accordance with EN 1992-1-1 (chapter 8.4) / NEN 6720 art. 9.6 and 9.16
Calculation Software			
ETA	 ETA-13/0222	 ETA-13/0401	

Halfen Demu fixing anchor

Typical applications / Load diagrams

Load behaviour

The following is an overview clarifying the load behaviour and the advantages of the different fixing anchor types as used in various main application.

The load behaviour — i.e. the load capacity as a function of different concrete classes — of certain types of T-FIXX® is compared with the corresponding types of Demu Bolt

anchors 1988, as illustrated in the diagrams.

A detailed calculation of the load behaviour (with all project specific influences; concrete strength, edge distances, etc.) can be done using the Halfen Software →

see chapter “Software”, pages 40–43.



Fixing anchor embedded in concrete (without edge influence)

Application 1:

The load capacity of the concrete is decisive, bolt anchors with higher steel strength than the T-FIXX® do not increase the load bearing capacity N_{Rd} of the anchoring system. Only the concrete strength and the effective anchorage length determine the load capacity of the system.

Example:

Short embedment length of fixing anchor (thin element).

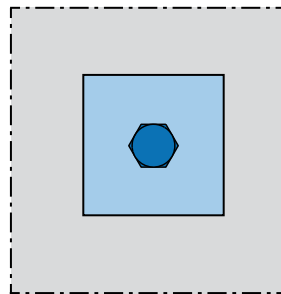

Top view: Fixing bolt with fixture anchored in concrete without edge influence.

Application 1

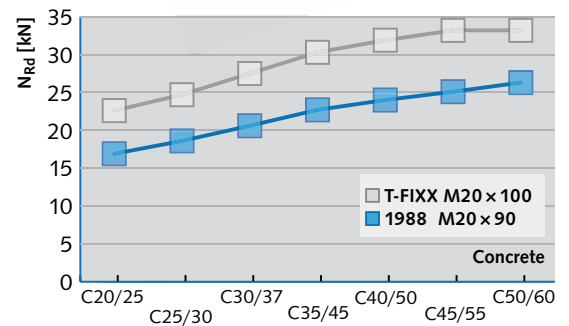

Diagram shows qualitative progression

Application 2:

The load capacity of the steel is decisive; steel strength is determined by the load bearing capacity of the anchoring system. The steel load capacity of the T-FIXX® has been reached and in contrast to bolt anchors — increasing concrete strength does not allow higher N_{Rd} values.

Example:

Long embedment length of the fixing anchor, high strength concrete

Application 2

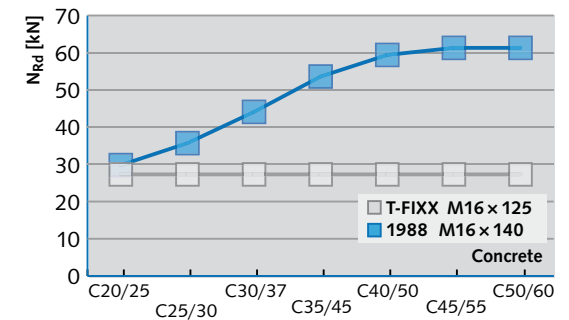

Diagram shows qualitative progression

Near edge anchor fixing

Application:

The load capacity of the concrete is decisive, bolt anchors with higher steel strength than the T-FIXX® do not increase the load bearing capacity N_{Rd} of the anchoring system. Only the concrete strength and the effective anchorage length determine the load capacity of the system.

Example:

Near edge application of fixing anchor.

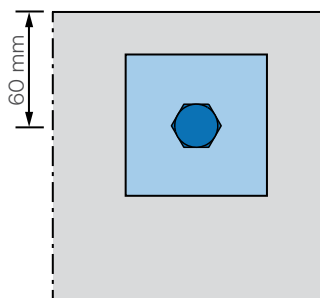

Top view: Fixing bolt with fixture anchored close to an edge in a concrete element.

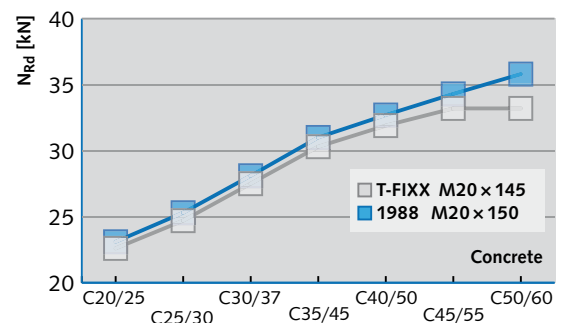

Diagram shows qualitative progression

Halfen Demu fixing anchor

Design concept

Planning standards apply for the whole of the European Union

The European standard EN 1992-4 was issued in 2019 and covers the design method for "Design of fastenings for use in concrete".

This approval standard represents current state of the art technology and may be used in practice.

To apply the European calculation method, product specific values such as load bearing capacities are necessary. These and further special regulations for dimensioning are included in the Halfen calculation software.

This calculation method is supported by a comprehensive user-oriented and easy-to-use design software.

What is the EN 1992-4 ?

A European CEN standard was created with the aim of standardising the dimensioning of fastenings in concrete to a common basis. Cast-in fixings such as headed fasteners as well as post-installed anchors are regulated in this standard.

The standards committee CEN / TC 250 / SC 2 / WG 2 "Design of fastenings for use in concrete" was founded in 2000 with members from nine European nations.

In 2009, the of regulations was published as CEN / TS 1992-4, TS = Technical Specification. The EN 1992-4 standard was published in 2019. This standard represents state of the art technology and may be used in practice.

This EN 1992-4 standard has five sections:

- General
- Headed bolts
- Anchor channels
- Dowels – Mechanical
- Dowels – Chemical

With the switchover to a single standard, this technical specification has become part of the European

EN 1992 Concrete Standard. With the publication of the ETA for T-FIXX® and Demu Bolt anchors, the publication of all resources and documents as well as personal consultations, the future is already being prepared.

The EN 1992-4 can be used if a technical specification is available for the fixings, which confirms the suitability of the product and contains the characteristic values necessary for dimensioning a fixing. For building products, an ETA (European Technical Assessment) represents this document.

The European Technical Assessment is a confirmation of the usability of a building product as defined by the Construction Products Regulation (CPR).

The ETA is based on tests, assessments and a technical evaluation by expert bodies appointed by the members of the EOTA. It comprises all product characteristics which are significant for compliance with statutory requirements in the member states, whereby the relevant requisite performance level may differ nationally or may depend on the intended purpose.

The resistances to steel failure are listed in the European Technical Assessment. The load bearing capacities are provided with calculations examples. Here all

influences on the load bearing capacity of the fixing anchor are taken into consideration. The Demu Fixing anchors may be used in all concrete strength classes from C20/25 to C90/105. The planned strength will be incorporated in the verifications.

The adaptable calculation concept allows for the progression in reinforced concrete construction towards using even lower component thicknesses with higher concrete strengths. For example, the resistance to concrete failure is 55% higher in a concrete of strength class C50/60 than in concrete of strength class C20/25. It is therefore possible to compensate for lower edge distances using a higher concrete strength.



Halfen Demu fixing anchor

Design concept

Verifications in accordance with EN/ 1992-4			
Tensile stress		Transverse stress	
Failure type	Verification	Failure type	Verification
steel failure of fastener	$N_{Ed} \leq N_{Rd,s}$	steel failure of fastener without lever arm	$V_{Ed} \leq V_{Rd,s}$
pull-out failure	$N_{Ed} \leq N_{Rd,p}$	steel failure of fastener with lever arm	$V_{Ed} \leq V_{Rd,s}$
concrete cone failure	$N_{Ed} \leq N_{Rd,c}$	concrete edge failure	$V_{Ed} \leq V_{Rd,c}$
splitting failure	$N_{Ed} \leq N_{Rd,sp}$	concrete pry-out failure	$V_{Ed} \leq V_{Rd,cp}$
blow-out failure 	$N_{Ed} \leq N_{Rd,cb}$	–	–

 Not required for fasteners with $c > 0,5 h_{ef}$

Notes regarding the table

- N_{Ed} and V_{Ed} are tension or shear stress respectively, acting on the fixing anchor.
- EN 1992-4 also regulates additional reinforcement; further verification must be provided here.

General information

Material codings

Following abbreviations and icons are used to illustrate the various materials and coatings used in this catalogue:

- WB Mill finished
- GV Zinc galvanized
- FV Hot-dip galvanized
- A4-50 Stainless steel, strength class 50
- A4-80 Stainless steel, strength class 80

Welding

All steel products in this catalogue are weldable. However, any welding, including tack welding, to our products can negatively influence their mechanical properties. Welding can affect the performance of the product.

If welding in the application is unavoidable, take the following into account:

- a possible change in performance; a possible reduction in load capacity
- remove any coating-layer before welding, and ensure welding fumes are safely extracted during welding
- use mandatory protective equipment
- the customer is responsible for making sure that applicable welding regulations are observed



Leviat is not liable for any damage caused to or by Demu products that have been subsequently welded.

Halfen Demu fixing anchor

Material and corrosion protection

Corrosion protection

Galvanizing:

Zinc galvanizing (GV)

Zinc galvanizing (chromium VI free) with a passivation treatment is used. The coating thickness is approximately 5–8µm.

After galvanizing, the products are dipped in a bichromate solution for passivation. The corrosion resistance is limited and depends on the immediate environment.

This does not apply to VEMO Socket anchors.

Hot-dip galvanizing (FV)

Hot-dip galvanizing can only be used for the following connectors and threaded anchor types: 1988, 1980-P, 1980-S, 1988-S, 4010, 4030, 1554 and 1558.

The connectors are first galvanized by dipping in a galvanizing bath of approx. 460°C and then cutting the internal thread. The thread is therefore not protected.

The coating layer of the subsequently screwed in hot-dip galvanized bolt provides corrosion protection to the thread in the connector. The thickness of the zinc coating is at least 45µm i.e. 55µm in accordance with EN-ISO 1461.

Stainless steel (A4)

Chromium is the most important alloying element in stainless steel. A specific chromium concentration ensures the generation of a passive layer on the surface of the steel that protects the base material against corrosion. This explains the high corrosion resistance of stainless steel.

Materials and their applications

Corrosion protection	Application
Zinc galvanized (GV)	Class 1: Non-critical corrosion exposure / Dry interior rooms Fixing anchors may only be used in structures subject to dry indoor environments (e. g. residential, offices, schools, hospitals, commercial retail).
Hot-dip galvanized (FV)	Class 2: Low corrosion exposure Fixing anchors may also be used in structures in unheated / uninsulated buildings where condensation may occur (e. g. warehouses, sport facilities, parking garages), as well as in structures not exposed to rain in exterior environments with low level of pollution (mostly rural areas).
Stainless steel (A4)	Class 3: Medium corrosion exposure Fixing anchors may also be used in structures exposed to outdoor environments (including industrial and marine environments) or exposed to permanently damp indoor conditions, if no particular aggressive conditions exist (e. g. permanent, alternating immersion in seawater).

T-FIXX® made entirely of stainless steel

The T-FIXX® A4 is made entirely of stainless steel; there is no requirement for minimal concrete cover as components cannot corrode.

Areas of application:

- bridge and tunnel projects (example, fixing of pipes)
- chemical industry (e. g. installations exposed to aggressive substances).
- all reinforced concrete elements with increased demands on the concrete cover.



No application for high levels of corrosion (corrosion resistance class IV in accordance with DIN EN 1993-1-4), when high concentrations of chlorides, sulphur and nitrogen oxides are present: For example road tunnels, structures in salt water or indoor swimming pools.

Halfen Demu fixing anchor

T-FIXX® anchors GV

General Information

The Halfen Demu T-FIXX® with European Technical Assessment is an innovative combination of socket anchor and bolt anchor. T-FIXX® has a unique, designed head and can be verified for every application.

The anchors are available in 22 standard versions/sizes in (GV) zinc galvanized or (A4) stainless steel.



ETA with fire protection classification



T-FIXX® GV

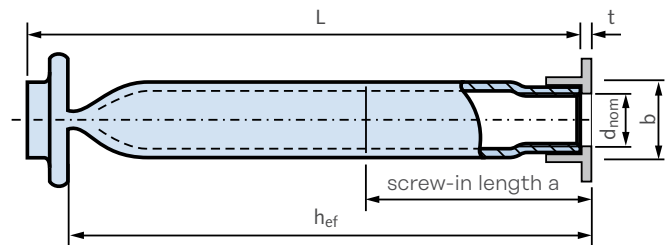

Anchor description

The T-FIXX® GV is manufactured from a steel precision tube (strength class E235). The surface is zinc galvanized (GV), the internal thread is metric ISO.

For identification a grey plastic clip is fitted (t=2mm).



Our free calculation software is available for download to calculate the anchors for each application in accordance with EN 1992-4.

www.halfen.com ► downloads ► software-cad-bim

See page 38 for more information on software.

T-FIXX® GV including (grey) identification clip								
Order no.	Dimensions				Design loads for tension ①		Design loads for shear ①	
	$d_{nom} \times L$	h_{ef}	a	b	$N_{Rd,c}$ [kN]	$N_{Rd,c}$ [kN]	$V_{Rd,c}$ [kN]	$V_{Rd,c}$ [kN]
	[mm]	[mm]	[mm]	[mm]	C20/25	C45/55	C20/25	C45/55
1000200625	M10 × 50	43.7	32.0	13.5	8.2	10.1	6.1	6.1
1000200626	M10 × 75	68.7	32.0	13.5	10.1	10.1	6.1	6.1
1000200627	M12 × 50	42.5	30.0	17.0	7.9	11.6	7.9	10.1
1000200628	M12 × 70	62.5	38.0	17.0	14.0	16.8	10.1	10.1
1000200629	M12 × 95	87.5	38.0	17.0	16.8	16.8	10.1	10.1
1000200630	M16 × 60	51.3	32.0	21.3	10.4	15.4	10.4	15.4
1000200631	M16 × 100	91.3	50.0	21.3	24.7	27.3	16.3	16.3
1000200632	M16 × 125	116.8	50.0	21.3	27.3	27.3	16.3	16.3
1000200633	M20 × 70	61.2	44.0	26.9	13.6	20.1	13.6	20.1
1000200634	M20 × 100	91.2	62.0	26.9	24.7	35.3	21.2	21.2
1000200635	M20 × 145	136.2	62.0	26.9	35.3	35.3	21.2	21.2

① The design load is the calculation value in accordance with EN 1992-4 for tensile or shear force in normal concrete without load-reducing influences. Values only apply for cracked concrete; no dense reinforcement (risk of shell spalling). The design loads are valid for application as permanent fixings. Not permitted for use in lifting applications!

Halfen Demu fixing anchor

T-FIXX® anchors A4

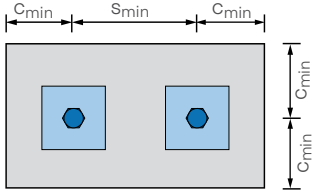

Top view:
Concrete member with 2 embedded fixing anchors.

Minimum allowed element thickness, minimum edge distances and spacings					
Thread size [mm]	d	M10	M12	M16	M20
Minimum spacing [mm]	S_{min}	100	100	100	120
Minimum edge distance [mm]	C_{min}	50	50	50	60
Minimum element thickness [mm]	h_{min}	$h_{nom} + C_{nom}$ ①			

h_{nom} : embedment depth; C_{nom} : concrete cover
 ① C_{nom} acc. to EN 1992-1 with $C_{nom} \geq 20$ mm
 Stainless steel fixing anchors; a minimum concrete cover $C_{nom} = 20$ mm is sufficient.

T-FIXX® A4

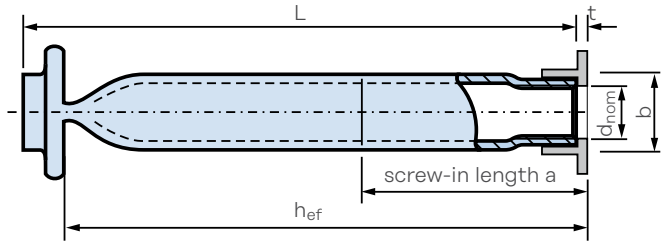

Anchor description

The T-FIXX® A4 is manufactured from a stainless steel tube (strength class A4-50). The internal thread is metric ISO. For identification a white plastic clip is fitted ($t=2$ mm).



Our free calculation software is available for download to calculate the anchors for each application in accordance with EN 1992-4.

www.halfen.com ► downloads ► software-cad-bim

See page 38 for more information on software.

T-FIXX® A4 including (white) identification clip

Order no.	Dimensions				Design loads for tension ②		Design loads for shear ②	
	$d_{nom} \times L$	h_{ef}	a	b	$N_{Rd,c}$ [kN]	$N_{Rd,c}$ [kN]	$V_{Rd,c}$ [kN]	$V_{Rd,c}$ [kN]
	[mm]	[mm]	[mm]	[mm]	C20/25	C45/55	C20/25	C45/55
1000200636	M10 × 50	43.7	32.0	13.5	8.2	8.9	5.4	5.4
1000200637	M10 × 65	58.7	32.0	13.5	8.9	8.9	5.4	5.4
1000200638	M12 × 50	42.5	30.0	17.2	7.9	11.6	7.9	9.4
1000200639	M12 × 70	62.5	38.0	17.2	14.0	15.6	9.4	9.4
1000200640	M12 × 115	107.5	38.0	17.2	15.6	15.6	9.4	9.4
1000200641	M16 × 60	51.3	32.0	21.3	10.4	15.4	10.4	14.9
1000200642	M16 × 80	71.3	50.0	21.3	17.1	25.0	14.9	14.9
1000200643	M16 × 110	101.3	50.0	21.3	25.0	25.0	14.9	14.9
1000200644	M20 × 70	61.2	44.0	26.9	13.6	20.1	13.6	19.4
1000200645	M20 × 100	91.2	62.0	26.9	24.7	32.3	19.4	19.4
1000200646	M20 × 125	116.2	62.0	26.9	32.3	32.3	19.4	19.4

② The design load is the calculation value in accordance with EN 1992-4 for tensile or shear force in normal concrete without load-reducing influences. Values only apply for cracked concrete; no dense reinforcement (risk of shell spalling). The design loads are valid for application as permanent fixings. Not permitted for use in lifting applications!

Halfen Demu fixing anchor

Bolt anchor 1988 GV



1988 GV

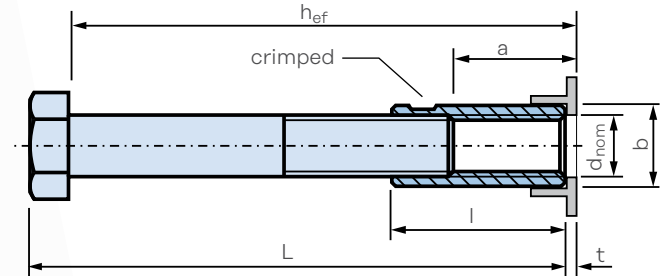

Anchor description

The bolt anchor 1988 GV consists of a hexagonal headed bolt (zinc galvanized, grade 8.8 acc. EN 4014/4017) with screwed and crimped sleeve.

The sleeve with internal metric ISO thread is manufactured from a steel precision tube and is zinc galvanized (GV).

For identification a grey plastic clip is fitted to the anchor ($t=2\text{mm}$).



Our free calculation software is available for download to calculate the anchors for each application in accordance with EN 1992-4.

www.halfen.com ► downloads ► software-cad-bim

See page 38 for more information on software.

Bolt anchor 1988 GV including (grey) identification clip

Order no.	Dimensions					Design loads for tension ①		Design loads for shear ①	
	$d_{\text{nom}} \times L$ [mm]	h_{ef} [mm]	a [mm]	b [mm]	l [mm]	$N_{\text{Rd,c}}$ [kN] C20/25	$N_{\text{Rd,c}}$ [kN] C45/55	$V_{\text{Rd,c}}$ [kN] C20/25	$V_{\text{Rd,c}}$ [kN] C45/55
1000201801	M12 × 55	49.0	25.0	15.5	35.0	9.7	14.4	9.7	14.4
1000200570	M12 × 100	94.0	25.0	15.5	35.0	16.7	28.9	17.3	17.3
4000200065	M12 × 150	144.0	25.0	15.5	35.0	16.7	28.9	17.3	17.3
1000200597	M16 × 75	67.0	31.0	21.0	45.0	15.5	23.1	31.1	35.2
4000200066	M16 × 140	132.0	31.0	21.0	45.0	29.8	58.8	35.2	35.2
4000200067	M16 × 220	212.0	31.0	21.0	45.0	29.8	58.8	35.2	35.2
1000200605	M20 × 90	79.0	37.0	26.0	55.0	19.9	29.5	39.8	52.9
1000200571	M20 × 150	139.0	37.0	26.0	55.0	46.4	68.9	52.9	52.9
1000200572	M20 × 180	169.0	37.0	26.0	55.0	46.5	88.2	52.9	52.9
1000200573	M20 × 270	259.0	37.0	26.0	55.0	46.5	88.2	52.9	52.9
1000200606	M24 × 110	97.0	48.0	32.0	70.0	27.1	40.2	54.1	80.3
1000200574	M24 × 200	187.0	48.0	32.0	70.0	67.0	107.5	83.1	83.1
1000202227	M24 × 320	307.0	48.0	32.0	70.0	67.0	138.7	83.1	83.1
1000200607	M30 × 160	143.0	62.0	40.0	90.0	48.5	71.9	96.9	126.9
1000200575	M30 × 240	223.0	62.0	40.0	90.0	94.4	140.0	126.9	126.9
1000200576	M30 × 380	363.0	62.0	40.0	90.0	112.6	211.7	126.9	126.9
1000202228	M36 × 300	279.0	76.0	47.5	110.0	132.0	195.9	185.8	185.8
1000202229	M36 × 420	399.0	76.0	47.5	110.0	160.2	309.8	185.8	185.8
1000202230	M42 × 300	276.0	70.0	54.0	110.0	129.9	192.7	222.8	222.8
1000200577	M42 × 460	436.0	70.0	54.0	110.0	227.4	371.5	222.8	222.8

① The design load is the calculation value in accordance with EN 1992-4 for tensile or shear force in normal concrete without load-reducing influences. Values only apply for cracked concrete; no dense reinforcement (risk of shell spalling). The design loads are valid for application as permanent fixings. Not permitted for use in lifting applications!

Halfen Demu fixing anchor

Bolt anchor 1988 FV



1988 FV

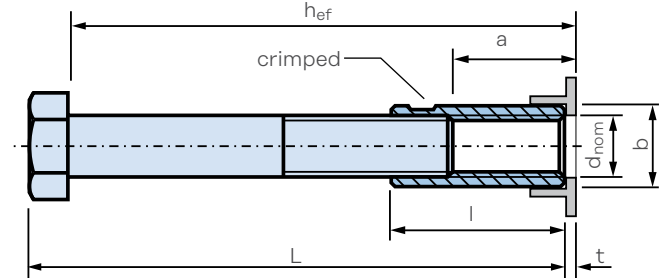

Anchor description

The bolt anchor 1988 FV consists of a bolt (zinc galvanized, grade 8.8 acc. EN ISO 4014/4017) with a screwed and crimped sleeve.

The sleeve with internal metric ISO thread is manufactured from a steel precision tube and is hot-dip galvanized (FV).

For identification a grey plastic clip is fitted (t=2 mm).



Our free calculation software is available for download to calculate the anchors for each application in accordance with EN 1992-4.

www.halfen.com ► downloads ► software-cad-bim

See page 38 for more information on software.

Bolt anchor 1988 FV including (grey) identification clip

Order no.	Dimensions					Design loads for tension ①		Design loads for shear ①	
	$d_{nom} \times L$ [mm]	h_{ef} [mm]	a [mm]	b [mm]	l [mm]	$N_{Rd,c}$ [kN]	$N_{Rd,c}$ [kN]	$V_{Rd,c}$ [kN]	$V_{Rd,c}$ [kN]
						C20/25	C45/55	C20/25	C45/55
1000200608	M12 × 55	49.0	25.0	15.5	35.0	9.1	13.7	9.1	13.7
1000200586	M12 × 100	94.0	25.0	15.5	35.0	16.8	29.0	17.3	17.3
1000200587	M12 × 150	144.0	25.0	15.5	35.0	16.8	29.0	17.3	17.3
1000200609	M16 × 75	67.0	31.0	21.0	45.0	14.8	21.8	29.1	35.2
1000200588	M16 × 140	132.0	31.0	21.0	45.0	29.8	58.9	35.2	35.2
1000200589	M16 × 220	212.0	31.0	21.0	45.0	29.8	58.9	35.2	35.2
1000200610	M20 × 90	79.0	37.0	26.0	55.0	18.6	27.9	37.3	52.9
1000200590	M20 × 150	139.0	37.0	26.0	55.0	43.5	65.2	52.9	52.9
1000200591	M20 × 180	169.0	37.0	26.0	55.0	46.5	87.4	52.9	52.9
1000200592	M20 × 270	259.0	37.0	26.0	55.0	46.5	88.4	52.9	52.9
1000200611	M24 × 110	97.0	48.0	32.0	70.0	25.4	38.0	50.7	76.0
1000200593	M24 × 200	187.0	48.0	32.0	70.0	67.0	101.8	83.1	83.1
1000202231	M24 × 320	307.0	48.0	32.0	70.0	67.0	138.9	83.1	83.1
1000202234	M30 × 160	143.0	62.0	40.0	90.0	45.4	68.1	90.8	126.9
1000200594	M30 × 240	223.0	62.0	40.0	90.0	88.4	132.5	126.9	126.9
1000200595	M30 × 380	363.0	62.0	40.0	90.0	112.6	212.0	126.9	126.9
1000200596	M36 × 420	399.0	76.0	47.5	110.0	160.2	310.4	185.8	185.8

① The design load is the calculation value in accordance with EN 1992-4 for tensile or shear force in normal concrete without load-reducing influences. Values only apply for cracked concrete; no dense reinforcement (risk of shell spalling). The design loads are valid for application as permanent fixings. Not permitted for use in lifting applications!

Halfen Demu fixing anchor

Bolt Anchors 1988 A4-80



1988 A4-80

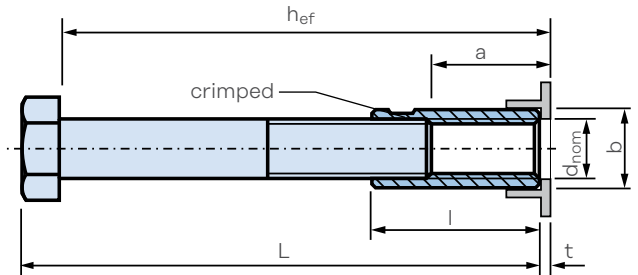

Anchor description A4-80

The bolt anchor 1988 A4 consists of a bolt (hot-dip galvanized, grade 8.8 or stainless steel A4-80 in accordance with EN ISO 4014/4017) with a screwed and crimped sleeve. The sleeve has an internal metric ISO thread and is manufactured from stainless steel (A4-80). For identification a black plastic clip is fitted ($t=2\text{mm}$).



Our free calculation software is available for download to calculate the anchors for each application in accordance with EN 1992-4.

www.halfen.com ► downloads ► software-cad-bim

See page 38 for more information on software.

Bolt anchor 1988 A4-80 (bolt 8.8 FV) including (black) dataclip

Order no.	Dimensions					Design loads for tension ①		Design loads for shear ①	
	$d_{nom} \times L$ [mm]	h_{ef} [mm]	a [mm]	b [mm]	l [mm]	$N_{Rd,c}$ [kN] C20/25	$N_{Rd,c}$ [kN] C45/55	$V_{Rd,c}$ [kN] C20/25	$V_{Rd,c}$ [kN] C45/55
1000200578	M12 × 100	94.0	25.0	15.5	35.0	16.7	36.8	24.0	24.0
1000200579	M12 × 150	144.0	25.0	15.5	35.0	16.7	36.8	24.0	24.0
1000200580	M16 × 140	132.0	31.0	21.0	45.0	29.8	63.7	47.2	47.2
1000200581	M16 × 220	212.0	31.0	21.0	45.0	29.8	65.5	47.2	47.2
1000200582	M20 × 150	139.0	37.0	26.0	55.0	46.5	68.9	73.2	73.2
1000200583	M20 × 180	169.0	37.0	26.0	55.0	46.5	92.3	73.2	73.2
1000200604	M20 × 270	259.0	37.0	26.0	55.0	46.5	102.4	73.2	73.2

Bolt anchor 1988 A4-80 (bolt A4-80) incl. identification clip (black)

on request	M12 × 100	94.0	25.0	15.5	35.0	16.7	36.8	24.0	24.0
	M12 × 150	144.0	25.0	15.5	35.0	16.7	36.8	24.0	24.0
	M16 × 140	132.0	31.0	21.0	45.0	29.8	63.7	47.2	47.2
	M16 × 220	212.0	31.0	21.0	45.0	29.8	65.5	47.2	47.2
	M20 × 150	139.0	37.0	26.0	55.0	46.5	68.9	73.2	73.2
	M20 × 180	169.0	37.0	26.0	55.0	46.5	92.3	73.2	73.2
	M20 × 270	259.0	37.0	26.0	55.0	46.5	102.4	73.2	73.2
	M24 × 200	187.0	48.0	32.0	70.0	67.0	107.5	106.2	106.2
M30 × 240	223.0	62.0	40.0	90.0	94.4	140.0	168.7	168.7	

① The design load is the calculation value in accordance with EN 1992-4 for tensile or shear force in normal concrete without load-reducing influences.

Values only apply for cracked concrete; no dense reinforcement (risk of shell spalling).

The design loads are valid for application as permanent fixings. Not permitted for use in lifting applications!

Halfen Demu fixing anchor

Bolt Anchors 1985 GV

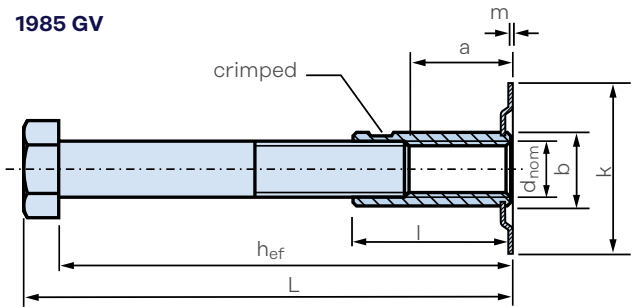

Anchor description

The bolt anchor 1985 GV is basically the same as anchor type 1988 GV but with an additional zinc nailing plate (to fix the anchor to formwork). The sleeve is zinc galvanized (GV), and has an internal metric ISO thread.



Our free calculation software is available for download to calculate the anchors for each application in accordance with EN 1992-4.

www.halfen.com ► downloads ► software-cad-bim

See page 38 for more information on software.

Bolt anchor 1985 GV

Order no.	Dimensions							Design loads for tension ①		Design loads for shear ①	
	$d_{nom} \times L$	h_{ef}	a	b	l	k	m	$N_{Rd,c}$ [kN]	$N_{Rd,c}$ [kN]	$V_{Rd,c}$ [kN]	$V_{Rd,c}$ [kN]
	[mm]	[mm]	[mm]	[mm]	[mm]	[mm]	[mm]	C20/25	C45/55	C20/25	C45/55
1000200612	M12 × 150	142.0	23.0	15.5	35.0	40.0	1.0	16.7	28.9	17.3	17.3
1000200613	M16 × 140	130.0	29.0	21.0	45.0	44.0	1.5	29.8	58.8	35.2	35.2
1000200614	M20 × 180	167.0	35.0	26.0	55.0	48.0	1.5	46.5	88.2	52.9	52.9
1000200615	M24 × 200	185.0	46.0	32.0	70.0	57.0	1.5	67.0	107.5	83.1	83.1

① The design load is the calculation value in accordance with CEN/TS 1992-4-1/2 for tensile or shear force in normal concrete without load-reducing influences.

Values only apply for cracked concrete; (applies to $h_{req} < 100$ mm).

The design loads are valid for application as permanent fixings. Not permitted for use in lifting applications!

Example of fixing anchors embedded in full concrete

Example of fixing anchors embedded in concrete without any influence of edge distances (c), centre to centre distances (s), etc.

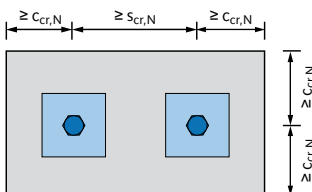

Top view: Concrete member with 2 fixing anchors, embedded in full concrete.

Boundary conditions (fixing anchors subjected only to tension loads)

$$c_{cr,N} \geq 1.5 \times h_{ef}$$

$$s_{cr,N} \geq 3.0 \times h_{ef}$$



The values apply for cracked concrete with reinforcement to absorb spalling that limit crack width to $w_k \leq 0.3$ mm).

Halfen Demu fixing anchor

Plate Anchor 1980-P GV / FV



1980-P GV / FV

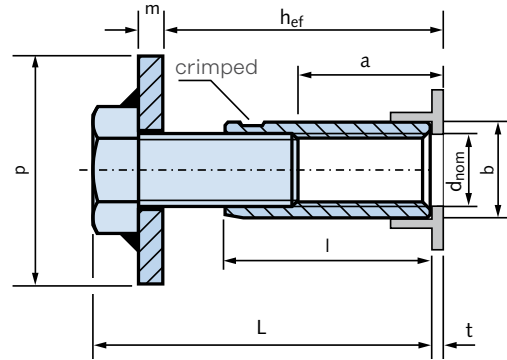

Anchor description

Plate anchors 1980-P GV and 1980-P FV consist of a bolt (GV mill-finished, grade 8.8 acc. ISO 4017) and a square washer (GV mill-finished, acc. DIN 436) welded to the underneath of the bolt head. The bolt is fitted to a screwed and crimped sleeve with internal metric ISO thread.

The surface of the sleeve is mill-finished (GV) or hot-dip galvanized (FV).

For identification a grey plastic clip is fitted ($t=2\text{ mm}$).



Our free calculation software is available for download to calculate the anchors for each application in accordance with EN 1992-4.

www.halfen.com ► downloads ► software-cad-bim

See page 40 for more information on software.

Plate anchor 1980-P GV

Order no.	Dimensions							Design loads for tension ^①		Design loads for shear ^①	
	$d_{\text{nom}} \times L$	h_{ef}	a	b	l	p	m	$N_{\text{Rd,c}}$ [kN]	$N_{\text{Rd,c}}$ [kN]	$V_{\text{Rd,c}}$ [kN]	$V_{\text{Rd,c}}$ [kN]
	[mm]	[mm]	[mm]	[mm]	[mm]	[mm]	[mm]	C20/25	C45/55	C20/25	C45/55
4000200069	M12 × 55	45.0	25.0	15.5	35.0	40.0	4.0	8.0	12.0	8.0	12.0
4000200397	M16 × 75	62.0	31.0	21.0	45.0	50.0	5.0	13.0	19.4	25.9	35.2
1000200616	M20 × 90	74.0	37.0	26.0	55.0	60.0	5.0	16.9	25.3	33.8	50.7
1000200617	M24 × 110	91.0	48.0	32.0	70.0	80.0	6.0	23.0	34.6	46.1	69.1
1000200618	M30 × 140	117.0	62.0	40.0	90.0	95.0	6.0	33.6	50.4	67.2	100.7

Plate anchor 1980-P FV incl. identification clip (grey)

1000200622	M12 × 55	45.0	25.0	15.5	35.0	40.0	4.0	8.0	12.0	8.0	12.0
1000202258	M16 × 75	62.0	31.0	21.0	45.0	50.0	5.0	13.0	19.4	25.9	35.2
1000202259	M20 × 90	74.0	37.0	26.0	55.0	60.0	5.0	16.9	25.3	33.8	50.7
1000202260	M24 × 110	91.0	48.0	32.0	70.0	80.0	6.0	23.0	34.6	46.1	69.1
1000200623	M30 × 140	117.0	62.0	40.0	90.0	95.0	6.0	33.6	50.4	67.2	100.7

① The design load is the calculation value according to CEN/TS 1992-4-1/2 for tensile or shear force in normal concrete without limitation of centre to centre distances, edge distances and element height (→ see explanation on page 19)! Values only apply for cracked concrete; no dense reinforcement (risk of shell spalling). The design loads are valid for application as permanent fixings. Not permitted for use in lifting applications!

Halfen Demu fixing anchor

Plate Anchor 1980-P A4-80



1980-P A4-80

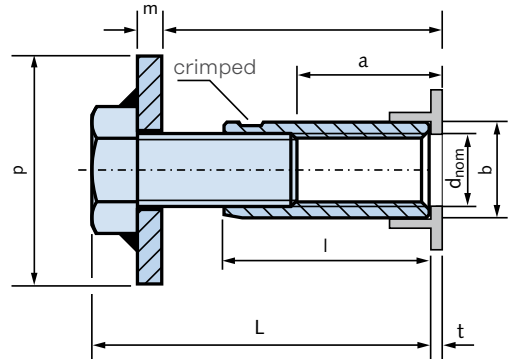

Anchor description

The plate anchor 1980-P A4-80 consists of a bolt (untreated, grade 8.8 acc. EN ISO 4017) and a square washer (untreated, acc. DIN 436) welded to the underneath of the bolt head. The bolt is fitted to a screwed and crimped sleeve with internal metric ISO thread.

The sleeve is manufactured from a stainless steel precision tube (strength class A4-80).

For identification a black plastic clip is fitted (t=2 mm).



Our free calculation software is available for download to calculate the anchors for each application in accordance with EN 1992-4.

www.halfen.com ► downloads ► software-cad-bim

See page 40 for more information on software.

Plate anchor 1980-P A4-80, including dataclip (black)

Order no.	Dimensions							Design loads for tension ①		Design loads for shear ①	
	$d_{nom} \times L$ [mm]	h_{ef} [mm]	a [mm]	b [mm]	l [mm]	p [mm]	m [mm]	$N_{Rd,c}$ [kN] C20/25	$N_{Rd,c}$ [kN] C45/55	$V_{Rd,c}$ [kN] C20/25	$V_{Rd,c}$ [kN] C45/55
1000200619	M12 × 55	45.0	23.0	15.5	35.0	40.0	4.0	8.0	12.0	8.0	12.0
1000200620	M16 × 75	62.0	29.0	21.0	45.0	50.0	5.0	13.0	19.4	25.9	38.9
1000202256	M20 × 90	74.0	35.0	26.0	55.0	60.0	5.0	16.9	25.3	33.8	50.7
1000200621	M24 × 110	91.0	46.0	32.0	70.0	80.0	6.0	23.0	34.6	46.1	69.1
1000202257	M30 × 140	117.0	60.0	40.0	90.0	95.0	6.0	33.6	50.4	67.2	100.7

① The design load is the calculation value according to EN 1992-4 for tensile or shear force in normal concrete without limitation of centre to centre distances, edge distances and element height (→ see explanation below)! Values only apply for cracked concrete; no dense reinforcement (risk of shell spalling). The design loads are valid for application as permanent fixings. Not permitted for use in lifting applications!

Minimum allowed element thickness, minimum edge distances and spacing

Installation parameters / layout of bolt anchors 1988, 1985 and plate anchor 180-P :

Top view: Concrete member with 2 embedded fixing anchors

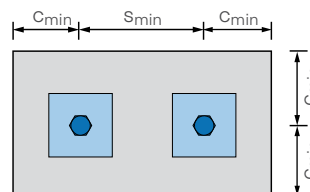

Minimum allowed element thickness, minimum edge distances and spacing

Thread size	d	[mm]	M12	M16	M20	M24	M30 ②	M36	M42	
Minimum spacing	S_{min}	[mm]	100	100	120	150	180	220	260	
Minimum edge distance	C_{min}	[mm]	50	50	60	75	90	110	130	
Minimum element thickness	h_{min} ③	[mm]	$h_{nom} + c_{nom}$ ②							

h_{nom} : embedment depth; c_{nom} : concrete cover ② c_{nom} in acc. with EN 1992-1 with $c_{nom} \geq 20$ mm ③ For 1980-P M30 x 140 applies $h_{nom} = 180$ mm

Halfen Demu fixing anchor

Bar Anchor 4010 GV



4010 GV

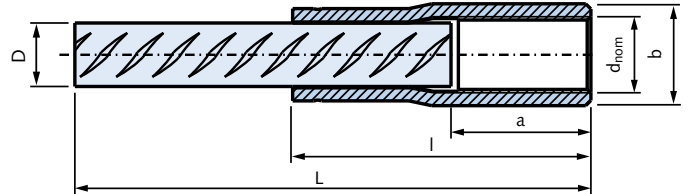

Anchor description

The bar anchor 4010 GV consists of a rebar B500B (untreated) in accordance with EN 10080 (NEN 6008) with crimped sleeve. The sleeve has an internal metric ISO thread and is zinc galvanized (GV).

Bar anchor 4010 GV							
Order no.	$d_{nom} \times L$ [mm]	D [mm]	Dimensions			A_s ① [mm ²]	Design loads ②
			a [mm]	b [mm]	l [mm]		$N_{Rd,s}$ [kN] Steel
1000001235	M16 × 415	12.0	25.0	21.0	58.0	113	48
1000001236	M16 × 615	12.0	25.0	21.0	58.0	113	48
1000001237	M16 × 840	12.0	25.0	21.0	58.0	113	48
1000001252	M16 × 1040	12.0	25.0	21.0	58.0	113	48
1000001238	M16 × 1540	12.0	25.0	21.0	58.0	113	48
1000001253	M16 × 2040	12.0	25.0	21.0	58.0	113	48
1000001239	M20 × 560	16.0	33.0	26.0	71.0	201	86
1000001240	M20 × 810	16.0	33.0	26.0	71.0	201	86
1000001241	M20 × 1060	16.0	33.0	26.0	71.0	201	86
1000001242	M20 × 1480	16.0	33.0	26.0	71.0	201	86
1000001254	M20 × 2240	16.0	33.0	26.0	71.0	201	86
1000001255	M20 × 3540	16.0	33.0	26.0	71.0	201	86
1000001243	M24 × 705	20.0	38.0	32.0	90.0	314	136
1000001244	M24 × 1005	20.0	38.0	32.0	90.0	314	136
1000001245	M24 × 1320	20.0	38.0	32.0	90.0	314	136
1000001246	M24 × 1840	20.0	38.0	32.0	90.0	314	136
1000001256	M24 × 2245	20.0	38.0	32.0	90.0	314	136
1000001258	M24 × 3540	20.0	38.0	32.0	90.0	314	136
1000001247	M30 × 1055	25.0	48.0	40.0	114.0	491	213
1000001248	M30 × 1555	25.0	48.0	40.0	114.0	491	213
1000001249	M30 × 2315	25.0	48.0	40.0	114.0	491	213
1000001259	M30 × 3555	25.0	48.0	40.0	114.0	491	213
1000001257	M42 × 1015	32.0	65.0	54.0	140.0	804	348
1000001250	M42 × 1490	32.0	65.0	54.0	140.0	804	348
1000001251	M42 × 2390	32.0	65.0	54.0	140.0	804	348
1000001260	M42 × 3590	32.0	65.0	54.0	140.0	804	348

① A_s : stress area of the reinforcement bar in mm².

② Design loads are the maximum values (yield strength) for the reinforcement bars and apply only for tension loads: $N_{Rd,s} = A_s \times f_{yd}$ ($f_{yd} = f_{yk}/1.15$). In addition, the load capacity of the bar anchor embedded in concrete has to be verified for compliance with EN 1992-1-1, chapter 8.4 (NEN 6720 art. 9.6 and 9.16). The required bonding strength depends mainly on the strength class of the concrete and has to be verified.

Halfen Demu fixing anchor

Bar Anchor 4010 FV



4010 FV

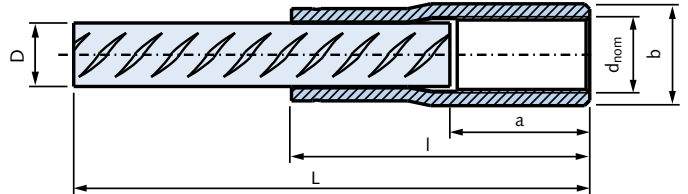

Anchor description

The bar anchor 4010 FV consists of a rebar B500B (untreated) in accordance with EN 10080 (NEN 6008) with a crimped sleeve.

The sleeve has a metric ISO thread and is hot-dip galvanized (FV).

Bar anchor 4010 FV

Order no.	$d_{nom} \times L$ [mm]	D [mm]	Dimensions			A_s ① [mm ²]	Design loads ②
			a [mm]	b [mm]	l [mm]		$N_{Rd,s}$ [kN] Steel
1000001261	M16 × 415	12.0	25.0	21.0	58.0	113	48
1000001265	M16 × 615	12.0	25.0	21.0	58.0	113	48
1000001262	M20 × 560	16.0	33.0	26.0	71.0	201	86
1000001266	M20 × 810	16.0	33.0	26.0	71.0	201	86
1000001263	M24 × 705	20.0	38.0	32.0	90.0	314	136
1000001267	M24 × 1005	20.0	38.0	32.0	90.0	314	136
1000001264	M30 × 1055	25.0	48.0	40.0	114.0	491	213
1000001268	M30 × 1555	25.0	48.0	40.0	114.0	491	213
1000001269	M42 × 1015	32.0	65.0	54.0	140.0	804	348

① A_s : stress area of the reinforcement bar in mm².

② Design loads are the maximum values (yield strength) for the reinforcement bars and apply only for tension loads: $N_{Rd,s} = A_s \times f_{yd}$ ($f_{yd} = f_{yk} / 1.15$). In addition, the load capacity of the bar anchor embedded in concrete has to be verified for compliance with EN 1992-1-1, chapter 8.4 (NEN 6720 art. 9.6 and 9.16). The required bonding strength depends mainly on the strength class of the concrete and has to be verified.

Technical Notes

The rebars of the bar anchors are manufactured with a tolerance of +0mm / -20mm (length of rebar) → the existing bonding length of the bar anchors can be calculated as follows:

$$L_{bd} = L - l - 2 \times D \text{ [mm]}$$

with

$$L_{bd} = \text{bonding length [mm]}$$

$$L = \text{total length of bar anchor [mm]}$$

$$l = \text{length of sleeve [mm]}$$

$$D = \text{diameter of rebar [mm]}$$

Halfen Demu fixing anchor

Bar Anchor 3016 GV

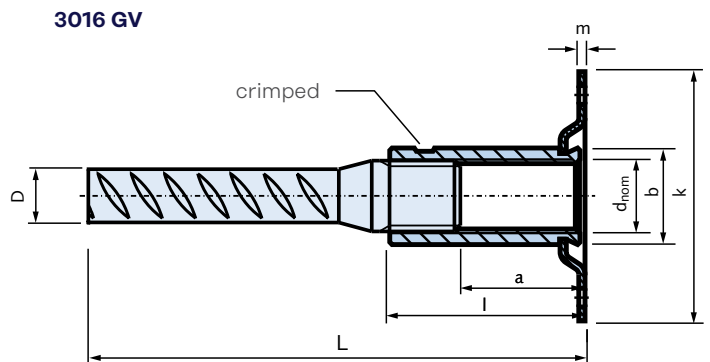

Anchor description

The bar anchor 3016 GV consists of a rebar B500B (untreated) in accordance with EN 10080 (NEN 6008) with a screwed and crimped sleeve and with additional nailing plate (to fix the anchor to the formwork).

The sleeve is zinc galvanized (GV) with an internal metric

ISO thread. The maximum screw-in length for bolts is longer compared to the 4010 bar anchor → see values in the table below.

Bar anchor 3016 GV									
Order no.	$d_{nom} \times L$ [mm]	D [mm]	Dimensions					A _s ① [mm ²]	Design loads ②
			a [mm]	b [mm]	l [mm]	k [mm]	m [mm]		N _{Rd,s} [kN] Steel
100020327	M16 × 410	12.0	29.0	21.0	45.0	44.0	1.5	113	48
100020328	M20 × 565	16.0	35.0	26.0	55.0	48.0	1.5	201	86
100020680	M24 × 715	20.0	46.0	32.0	70.0	57.0	1.5	314	136

① A_s: stress area of the reinforcement bar in mm².

② Design loads are the maximum values (yield strength) for the reinforcement bars and apply only for tension loads: $N_{Rd,s} = A_s \times f_{yd}$ ($f_{yd} = f_{yk} / 1.15$). In addition, the load capacity of the bar anchor embedded in concrete has to be verified for compliance with EN 1992-1-1, chapter 8.4 (NEN 6720 art. 9.6 and 9.16). The required bonding strength depends mainly on the strength class of the concrete and has to be verified.

Technical Notes

The rebars of the bar anchors are manufactured with a tolerance of +0 mm / -20 mm (length of rebar) → the existing bonding length of the bar anchors can be calculated as follows:

$$L_{bd} = L - l - 2 \times D \text{ [mm]}$$

with

$$L_{bd} = \text{bonding length [mm]}$$

$$L = \text{total length of bar anchor [mm]}$$

$$l = \text{length of sleeve [mm]}$$

$$D = \text{diameter of rebar [mm]}$$

Halfen Demu fixing anchor

Bar Anchor 3010 A4-80



3010 A4-80

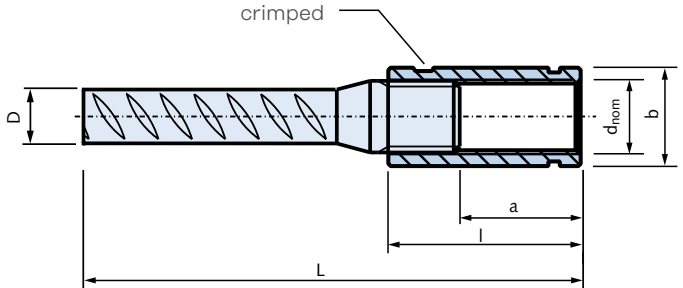

Anchor description

The bar anchor 3010 A4-80 consists of a rebar B500B (untreated) in accordance with EN 10080 (NEN 6008)

with a screwed and crimped sleeve.

The sleeve has a metric ISO thread and is made of stainless steel (strength class A4-80).

Bar anchor 3010 A4-80

Order no.	$d_{nom} \times L$ [mm]	D [mm]	Dimensions			A_s ① [mm ²]	Design loads ②
			a [mm]	b [mm]	l [mm]		$N_{Rd,s}$ [kN] Steel
4000200072	M16 × 410	12.0	29.0	21.0	45.0	113	48
4000200073	M20 × 565	16.0	35.0	26.0	55.0	201	86
4000200074	M24 × 715	20.0	46.0	32.0	70.0	314	136
4000200461	M30 × 1055	25.0	60.0	40.0	90.0	491	213

① A_s : stress area of the reinforcement bar in mm².

② Design loads are the maximum values (yield strength) for the reinforcement bars and apply only for tension loads: $N_{Rd,s} = A_s \times f_{yd}$ ($f_{yd} = f_{yk} / 1.15$). In addition, the load capacity of the bar anchor embedded in concrete has to be verified for compliance with EN 1992-1-1, chapter 8.4 (NEN 6720 art. 9.6 and 9.16). The required bonding strength depends mainly on the strength class of the concrete and has to be verified.

Technical Notes

The rebars of the bar anchors are manufactured with a tolerance of +0mm / -20mm (length of rebar)
→ the existing bonding length for bar anchors can be calculated as follows:

$$L_{bd} = L - l - 2 \times D \text{ [mm]}$$

with

L_{bd} = bonding length [mm]

L = total length of bar anchor [mm]

l = length of sleeve [mm]

D = diameter of the rebar [mm]

Halfen Demu fixing anchor

Bar Anchor 1988-S GV



1988-S GV

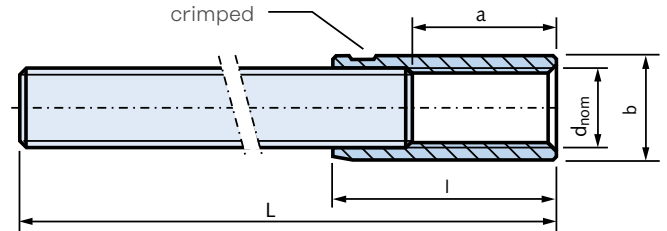

Anchor description

The bar anchor 1988-S GV consists of a threaded rod (untreated, quality 8.8) with a screwed and crimped sleeve. The sleeve has a metric ISO thread and the surface is zinc galvanized (GV).

Alternatively, sleeves are available on request as hot-dip galvanized or in stainless steel.

Bar anchor 1988-S GV

Order no.	$d_{nom} \times L$ [mm]	Dimensions			A_s ① [mm ²]	Design loads②
		a [mm]	b [mm]	l [mm]		$N_{Rd,s}$ [kN] Steel
1000202262	M12 × 435	23.0	15.5	35.0	84	33
1000210263	M12 × 635	23.0	15.5	35.0	84	33
1000200624	M16 × 585	29.0	21.0	45.0	161	63
1000210266	M20 × 735	35.0	26.0	55.0	245	96

① A_s : stress area of the threaded connector in mm².

② Design loads are the maximum values (yield strength) for the threaded rod and apply only for tension loads:

In addition, the load capacity of the bar anchor embedded in concrete has to be threaded for compliance with EN 1992-1-1, chapter 8.4 (NEN 6720 art. 9.6 and 9.16).

The required bonding strength depends mainly on the strength class of the concrete and has to be verified.

Technical Notes

The existing bonding length of bar anchors can be calculated as follows:

$$L_{bd} = L - l \text{ [mm]}$$

with

L_{bd} = bonding length [mm]

L = total length of bar anchor [mm]

l = length of sleeve [mm]

Halfen Demu fixing anchor

Bar Anchor 4030 GV / FV



4030 GV / FV

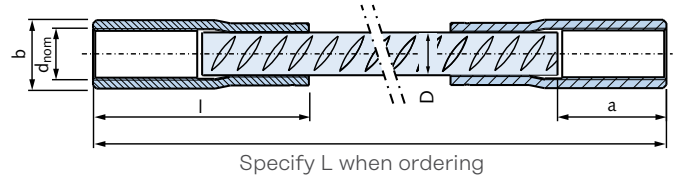

Anchor description

The special bar anchors 4030 GV and 4030 FV consist of a rebar B500B (untreated) in accordance with EN 10080 (NEN 6008) with a crimped sleeve on both ends.

The sleeves have internal metric ISO threads and are available either in zinc galvanized (GV) or hot-dip galvanized (FV). This product is made on request; please specify required length when ordering.

Bar anchor 4030 GV								
Order no.	d _{nom} – D [mm]	L min [mm]	Dimensions				A _s ① [mm ²]	Design loads ② N _{Rd,s} [kN] Steel
			a [mm]	b [mm]	l [mm]			
1000202334	M16 - ø12	235.0	25.0	21.0	58.0	113	48	
1000202335	M20 - ø16	235.0	33.0	26.0	71.0	201	86	
1000202336	M24 - ø20	235.0	38.0	32.0	90.0	314	136	
1000202337	M30 - ø25	250.0	48.0	40.0	114.0	491	213	
1000202338	M42 - ø32	350.0	65.0	54.0	140.0	804	348	
Bar anchor 4030 FV								
1000202340	M16 - ø12	235.0	25.0	21.0	58.0	113	48	
1000202341	M20 - ø16	235.0	33.0	26.0	71.0	201	86	
1000202342	M24 - ø20	235.0	38.0	32.0	90.0	314	136	
1000202343	M30 - ø25	250.0	48.0	40.0	114.0	491	213	

① A_s: stress area of the reinforcement bar in mm².
 ② Design loads are the maximum values (yield strength) for the reinforcement bars and apply only for tension loads:
 $N_{Rd,s} = A_s \times f_{yd}$ ($f_{yd} = f_{yk} / 1.15$).
 In addition, the load capacity of the bar anchor embedded in concrete has to be verified for compliance with EN 1992-1-1, chapter 8.4 (NEN 6720 art. 9.6 and 9.16).
 The required bonding strength depends mainly on the strength class of the concrete and has to be verified.

Halfen Demu fixing anchor

Spacer 1558 GV / FV

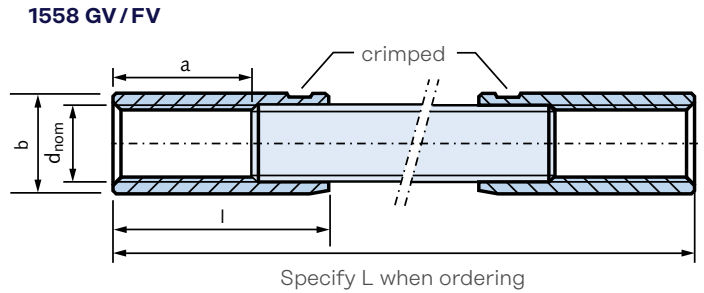

Anchor description

The bar anchors (spacer) 1558 GV and 1558 FV consist of a threaded rod (untreated, grade 8.8) with screwed and crimped sleeves on both ends. The sleeves have internal metric ISO threads and are available either zinc galvanized (GV) or hot-dip galvanized (FV). This product is made on request; please specify required length when ordering.

Spacer 1558 GV							
Order no.	d _{nom} [mm]	L min [mm]	Dimensions			A _s ① [mm ²]	Design loads ②
			a [mm]	b [mm]	l [mm]		N _{Rd,s} [kN] Steel
1000210271	M12	200.0	23.0	15.5	35.0	84	33
1000202269	M16	200.0	29.0	21.0	45.0	161	63
1000202270	M20	200.0	35.0	26.0	55.0	245	96
1000202271	M24	200.0	46.0	32.0	70.0	385	150
1000202272	M30	220.0	60.0	40.0	90.0	605	237
Spacer 1558 FV							
1000210270	M12	200.0	23.0	15.5	35.0	84	33
1000202273	M16	200.0	29.0	21.0	45.0	161	63
1000209956	M20	200.0	35.0	26.0	55.0	245	96
1000202274	M24	200.0	46.0	32.0	70.0	385	150
1000202275	M30	220.0	60.0	40.0	90.0	605	237

① A_s: stress area of the threaded connector in mm².

② Design loads are the maximum values (yield strength) for the threaded rods and apply only for tension loads. In addition, the load capacity of the bar anchor embedded in concrete has to be verified for compliance with EN 1992-1-1, chapter 8.4 (NEN 6720 art. 9.6 and 9.16).

The required bonding strength depends mainly on the strength class of the concrete and has to be verified.

Halfen Demu fixing anchor

Spacer 1558 A4-80



1558 A4-80

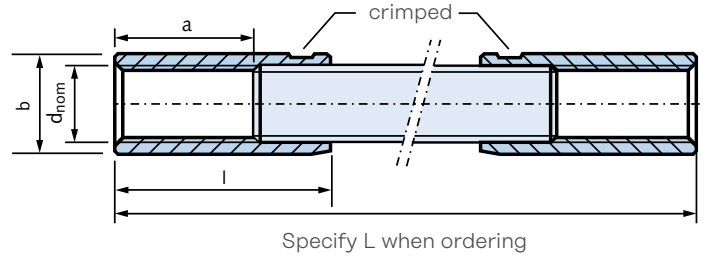

Anchor description

The bar anchor 1558 A4-80 consists of a threaded rod (mill-finished, grade 8.8) with screwed and crimped sleeves on both ends. The sleeves are made of stainless steel (strength class A4-80) and have internal metric ISO threads. This product is made on request; please specify required length when ordering.

Spacer 1558 A4-80							
Order no.	d _{nom} [mm]	L min [mm]	Dimensions			A _S ① [mm ²]	Design loads ②
			a [mm]	b [mm]	l [mm]		N _{Rd,s} [kN] Steel
1000202276	M12	200.0	23.0	15.5	35.0	84	45
1000202277	M16	200.0	29.0	21.0	45.0	157	84
1000202278	M24	200.0	46.0	32.0	70.0	355	189
1000202279	M30	220.0	60.0	40.0	90.0	560	299

① A_S: stress area of screwed in bolt/bar in mm².

② Design loads are the maximum values (yield strength) for the threaded rods and apply only for tension loads.. In addition, the load capacity of the bar anchor embedded in concrete has to be verified for compliance with EN 1992-1-1, chapter 8.4 (NEN 6720 art. 9.6 and 9.16). The required bonding strength depends mainly on the concrete strength class and has to be verified.

Halfen Demu fixing anchor

Bending of bar anchors

Custom bending

On request, some types of Halfen Demu bar anchors can be bent to customer's specifications — L shaped or U shaped. The bending roll diameter (d_{BR}) and the required anchor length for the bar anchor must be determined in accordance with applicable national regulations.



- 1988-S 8.8 type anchors cannot be bent!
- Bar anchors are bent to order, please contact us for lead times

1980-S

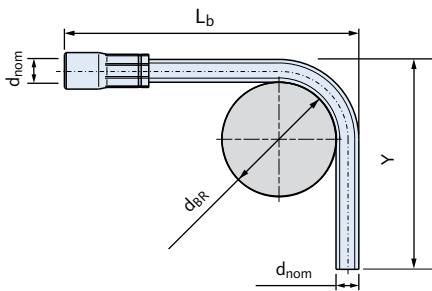

1980-S			
Bending L	d_{nom} [mm]	Y min [mm]	L_b min [mm]
max. 1250mm	M12	200.0	145.0
max. 1250mm	M16	200.0	165.0
max. 1250mm	M20	200.0	195.0

Note: Required bonding length has to be verified acc. to valid national standards

4010

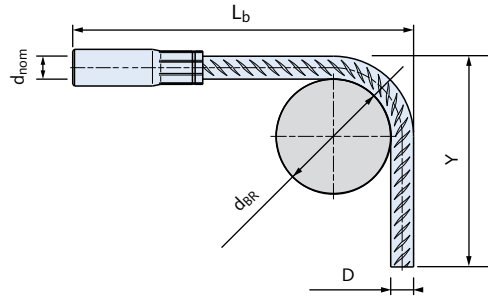

4010			
D [mm]	d_{nom} [mm]	Y min [mm]	L_b min [mm]
ø12	M16	200.0	140.0
ø16	M20	200.0	160.0
ø20	M24	200.0	210.0
ø25	M30	290.0	275.0
ø32	M42	330.0	325.0

Note: Required bonding length has to be verified in acc. with valid national standards

3010 – 3016

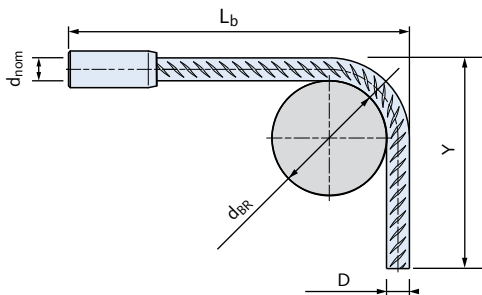

3010 – 3016			
D [mm]	d_{nom} [mm]	Y min [mm]	L_b min [mm]
ø12	M16	200.0	145.0
ø16	M20	200.0	185.0
ø20	M24	200.0	215.0
ø25	M30	290.0	280.0

Note: Required bonding length has to be verified acc. to valid national standards

U-shaped bar anchors 4030

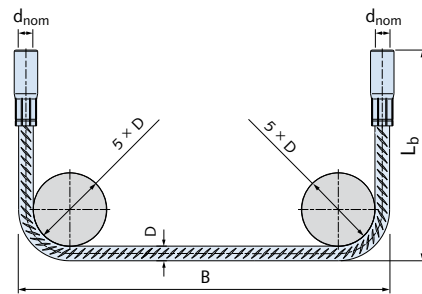

U-shaped			
D [mm]	d_{nom} [mm]	B min [mm]	L_b min [mm]
ø12	M16	140.0	140.0
ø16	M20	165.0	160.0
ø20	M24	210.0	210.0
ø25	M30	290.0	275.0
ø32	M42	350.0	325.0

Note: Required bonding length has to be verified acc. to valid national standards

Halfen Demu fixing anchor

Demu Accessories

Accessories

We provide numerous accessories to facilitate the installation of all anchoring systems.

See page 34 for further information on installation.

2250

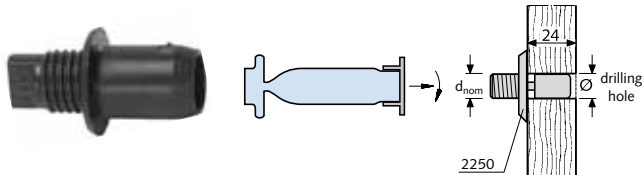

Fixing pin

- hammer the fixing pin into the hole in the formwork
- screw-on the anchor
- pour the concrete; after the concrete has cured remove the formwork
- the fixing pin shears off when removing the formwork
- remove thread part of the fixing pin

2250				
Order no.	d _{nom} [mm]	Drilling [mm]	Colour	Breaking load (shear) [kN]
3000020612	M6	ø11×23	green	0.6
3000023024	M8	ø11×23	blue	0.6
3000023025	M10	ø11×23	yellow	0.6
3000020613	M12	ø11×23	red	0.6
3000020614	M16	ø17×24	black	0.9
3000023026	M20	ø17×24	white	0.9
3000023027	M24	ø17×24	blue	0.9

2282

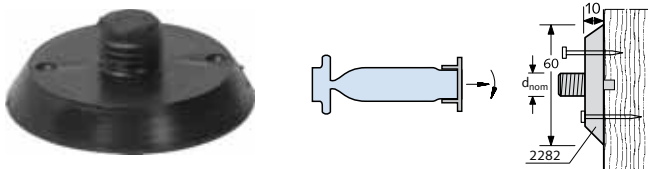

Nailing plate h = 10 mm, with nail holes and fixing pin

2282				
Order no.	d _{nom} [mm]	h [mm]	ø [mm]	Colour
3000023042	M16	10	60	black
3000023043	M20	10	60	yellow

2280

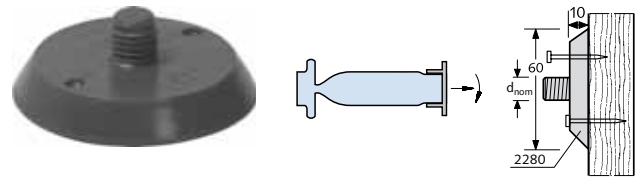

Nailing plate h = 10 mm, with nail holes

2280				
Order no.	d _{nom} [mm]	h [mm]	ø [mm]	Colour
3000020605	M8	10	60	grey
3000020606	M10	10	60	yellow
3000020607	M12	10	60	red
3000020608	M16	10	60	black
3000020609	M20	10	60	light-green
3000020610	M24	10	60	black
3000020611	M30	7	60	dark-green

2275

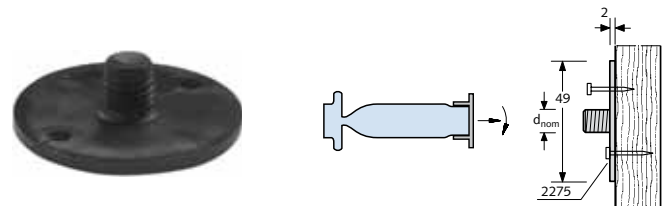

Nailing plate h = 2 mm, with nail holes

2275				
Order no.	d _{nom} [mm]	h [mm]	ø [mm]	Colour
3000020621	M10	2	49	white
3000020622	M12	2	49	black
3000020623	M16	2	49	green
3000020624	M20	2	49	red
3000020625	M24	2	49	yellow

Halfen Demu fixing anchor

Demu Accessories

2600

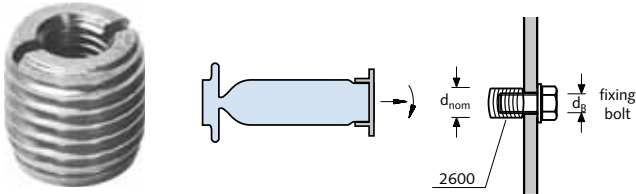

Thread adapter

Reduces the diameter of holes in formwork.
Zinc galvanized and reusable.

2600		
Order no.	d _{nom} [mm]	d _B [mm]
3000020616	M12	M6
3000020617	M16	M8
3000020618	M20	M8
3000020619	M24	M10
3000020620	M30	M10
3000023036	M36	M10
3000023037	M42	M12
3000023038	M48	M16

d_B = Diameter of fixing bolt
length of thread adapter l = 16 mm

2244

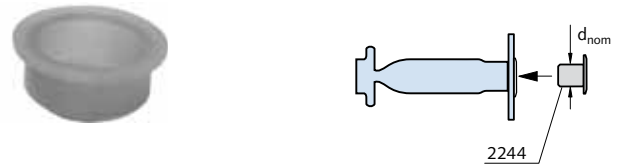

Sealing cap

Protects the thread against concrete, dirt and water.

2244			
Order no.	d _{nom} [mm]	Size [mm]	Colour
1000202284	M8	7.0	red
1000200649	M10	9.0	red
1000200650	M12	11.0	red
4000200071	M16	14.5	black
1000200651	M20	18.0	blue
1000202285	M24	21.5	red
3000023029	M30	27.0	white
3000023030	M36	33.5	white
3000023031	M42	38.4	white

Anchor groups — positioning plates (templates) for easy installation

Positioning plate

Our positioning plates (templates) allow easy and precise installation of groups of 2 up to 8 fixing anchors.

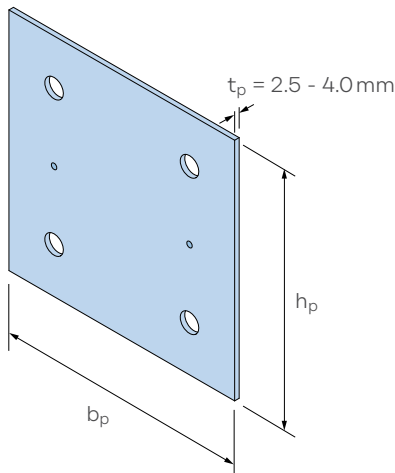

Positioning plate	
Order no.	Material
1060.409-00001	Zinc galvanized/Hot-dip galvanized
1060.409-00003	Stainless steel A4

Specifications required for orders

- Please supply detailed drawings
- Positioning plate: b_p, h_p, number, position and diameter of bolt-holes, type of corrosion-protection, position and diameter of nail-holes.

Further details and assembly see page 34.

Halfen Demu fixing anchor

Demu Accessories

Anchor groups — positioning plate (template) for easy installation

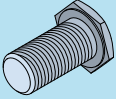
Flat-headed assembly bolt for positioning plate – 3 mm head				
	Article name: type nominal size	Order no.	Nominal size	Length L [mm]
	Flat-headed bolt M12	3000021795	M12	20
	Flat-headed bolt M16	3000021793	M16	25
	Flat-headed bolt M20	3000021793	M20	25

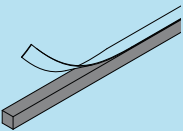
Sealing accessory for concreting			
	Article name	Order no.	Description
	Foam tape	3000021796	Self-adhesive foam tape 15 x 15mm, length 1000mm

Positioning plate – assembly steps

- 1 Halfen Demu Fixing anchors with fitted data caps are screwed onto the prefabricated positioning plate using flat headed bolts (bolt-head 3 mm).
- 2 Cut stripes of self-adhesive foam tape and fix between the positioning plate and the formwork, to prevent concrete seepage.
- 3 The positioning plate with the attached fixing anchors is fitted with nails to timber formwork or with magnets to steel formwork. Long and heavy fixing anchors, bolt anchor 1988 M24 x 320 or bigger, should be additionally wire-tied to the reinforcement.
After the concrete has cured and the formwork has been removed, the flat headed bolts can be unscrewed and the positioning plate is removed. Use sealing caps to protect the threads against water and dirt before final installation.

- 4 The secondary component is bolted in position.

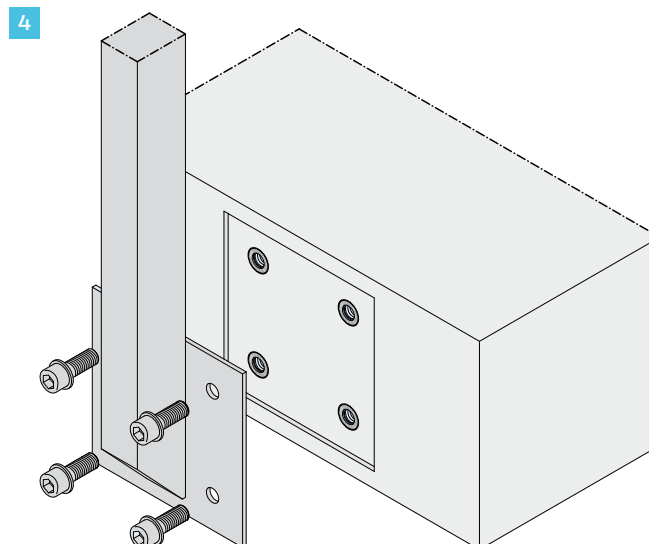
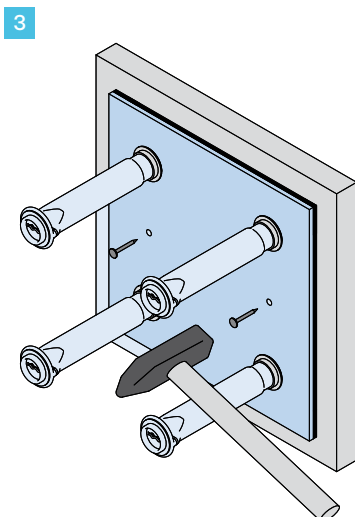
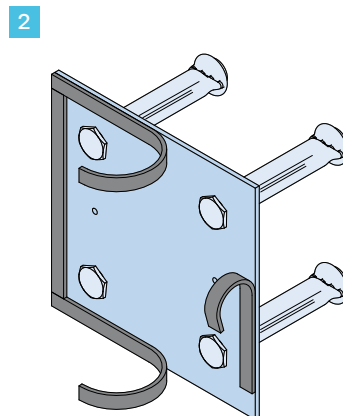
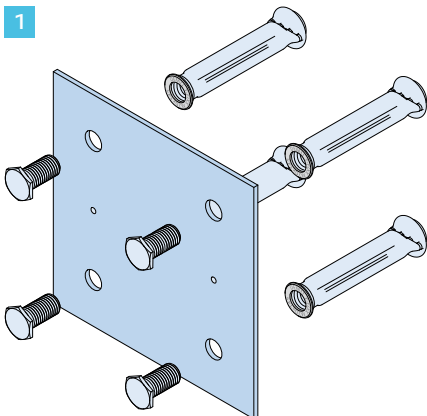

Halfen Demu fixing anchor

Fixing Anchors

Assembly

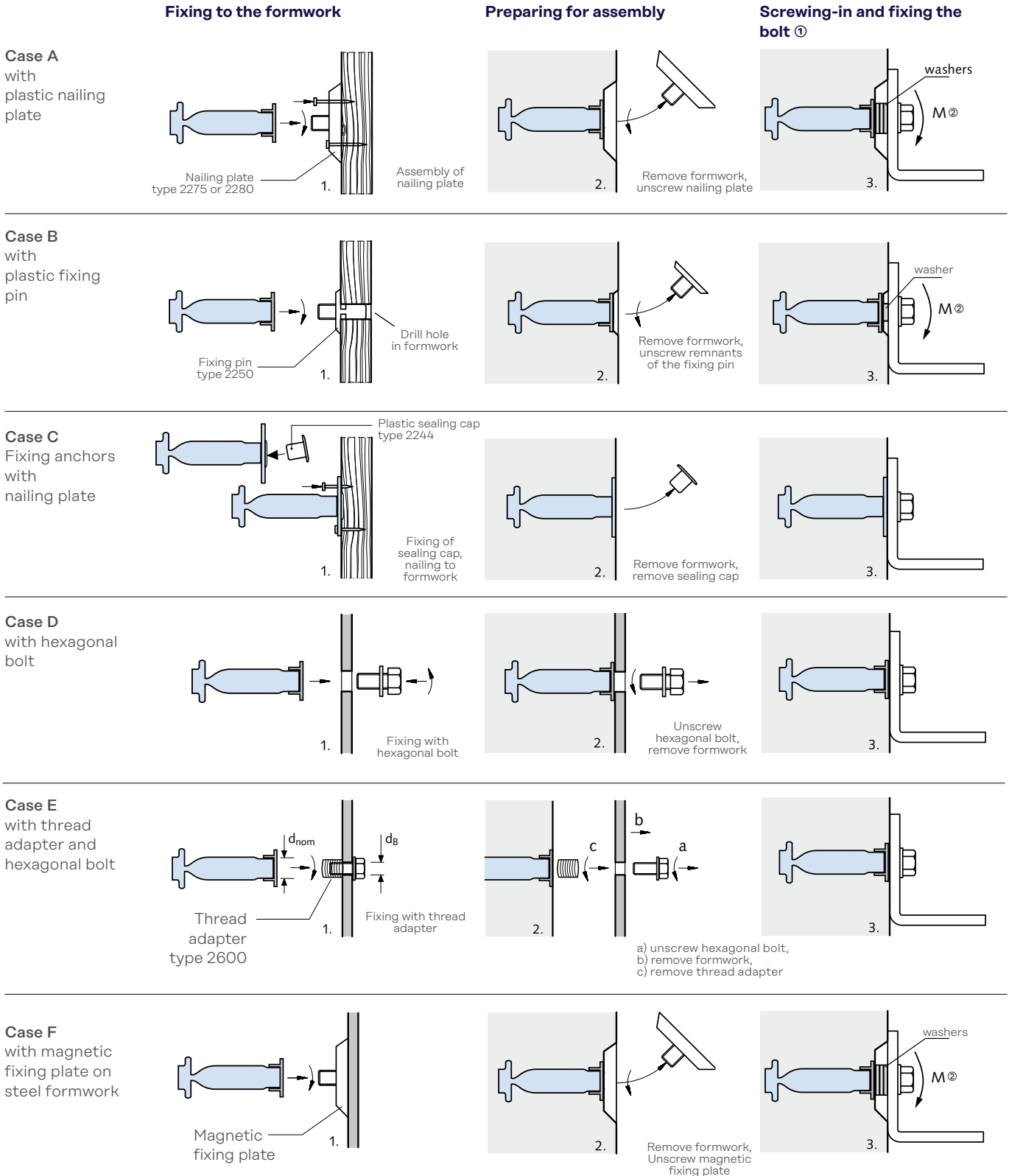

① Torque Tinst → see table on page 35

Ⓜ Bending of bolt in case of recessed cast anchor must be taken into consideration and must be verified! (Bolts are not included in scope of delivery)

Halfen Demu fixing anchor

Fixing Anchors and Accessories

Installation parameters

General notes on installation

Before installing the fixing components, check whether the inside of the sockets and sleeves are dry and clean. To guarantee best possible bond between the fixing anchor and the concrete, make sure the surface of the anchor is free from dirt, oil, etc.

The concrete has to be poured carefully; avoid direct contact between the compacting device (vibrators) and the fixing anchor. The fixing anchors may be embedded flush or recessed in the concrete. It is strongly recommended to use washers to shim secondary components if the anchors are recessed.

After striking the formwork, the inside of the threaded sockets must be protected against ingress of water, dirt or oil until required for use i.e. for fixing secondary components.

Even after final assembly ensure the inside of the socket remains dry.

The fixing component (bolt with standard metric thread) has to be selected in accordance with the static engineer's specifications. Minimum screw-in length(s) for bolts and maximum installation torque (T_{inst}) can be found in the adjacent tables.

The fixing anchor must not be subjected to full load capacity until the concrete has reached its final strength.

T-FIXX®		
Thread-size	Minimum screw-in length s [mm]	Torque T_{inst} [Nm]*
M10	17.0	≤ 8
M12	20.0	≤ 10
M16	26.0	≤ 30
M20	32.0	≤ 60

Bolt anchor 1988		
Thread-size	Minimum screw-in length s [mm]	Torque T_{inst} [Nm]*
M12	16.4	≤ 10
M16	21.2	≤ 30
M20	26.0	≤ 50
M24	30.8	≤ 90
M30	38.0	≤ 180
M36	45.2	≤ 250
M42	52.4	≤ 300

Bolt anchor 1985		
Thread-size	Minimum screw-in length s ^① [mm]	Torque T_{inst} [Nm]*
M12	18.0	≤ 10
M16	24.0	≤ 30
M20	30.0	≤ 50
M24	36.0	≤ 90

① value $s = 1.5 \times d_{nom}$

Bolt anchor 1980-P / Bar anchor		
Thread-size	Minimum screw-in length s ^② [mm]	Torque T_{inst} [Nm]*
M12	14.4	≤ 10
M16	19.2	≤ 30
M20	24.0	≤ 50
M24	28.8	≤ 90
M30	36.0	≤ 180
M36	43.2	≤ 250
M42	50.4	≤ 300

② value $s = 1.2 \times d_{nom}$; for bar anchors type 3016 (with integrated nailing plates), increase the values by 25% → ($s = 1.5 \times d_{nom}$)

Socket anchors		
Thread-size	Minimum screw-in length s ^③ [mm]	Torque T_{inst} [Nm]*
M6	7.2	≤ 1
M8	9.6	≤ 2
M10	12.0	≤ 4
M12	14.4	≤ 8
M16	19.2	≤ 17
M20	24.0	≤ 25
M24	28.8	≤ 53
M30	36.0	≤ 96

③ value $s = 1.2 \times d_{nom}$; for socket anchors type 1130, 1136-G (with integrated nailing plates), increase the values by 25% → ($s = 1.5 \times d_{nom}$)

* The tightening torques apply for unlubricated bolts.

Multilingual installation instruction for Demu Fixing anchors can be found at www.halfen.com

Halfen Demu fixing anchor

Fixing components – Assembly instruction

Determining the required bolt length

General

The fixture is attached to the cast-in anchor with a standard metric thread fixing bolt and washer or a threaded rod, a washer and a nut.

The fixing components are not included with the Demu Fixing systems and have to be ordered separately. The fixing component (bolt) has to be selected in accordance with the static engineer's specifications.

Screw-in length of bolt

For all fixing anchors the minimum and a maximum screw-in lengths must be observed. The minimum values can be found in a table in chapter "Installation instructions", page 35. The corresponding maximum values for each anchor type can be found in the technical description (tables) of the respective product (pages 14 – 32). To find the required bolt length, proceed as described below.

Determining the required bolt length (L_s)

Bolt length (L_s)

$$L_{s,min} = s + k \text{ (minimum bolt length)}$$

$$L_{s,max} = a + k \text{ (maximum bolt length)}$$

k = clamp thickness (thickness of the steel angle bracket and the washers)

s = minimum screw-in length (→ see tables on page 35)

a = maximum screw-in length (→ see tables on pages 14 – 32)

Example for determining bolt length

Recessed T-FIXX® M12×70
secured to the framework with a plastic nailing plate (type 2275)

$$L_{s,min} = 1.5 \times d_{nom} + k = 18 + 17 = 35$$

$$L_{s,max} = a + k = 36 + 17 = 53$$

→ bolt M12×40

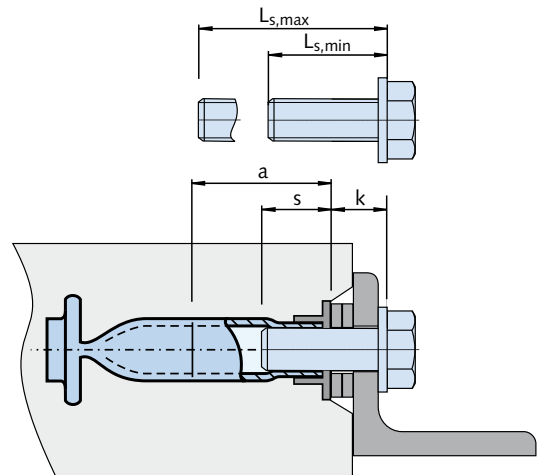

Fixing T-FIXX® M12×70 to formwork with plastic nailing plate

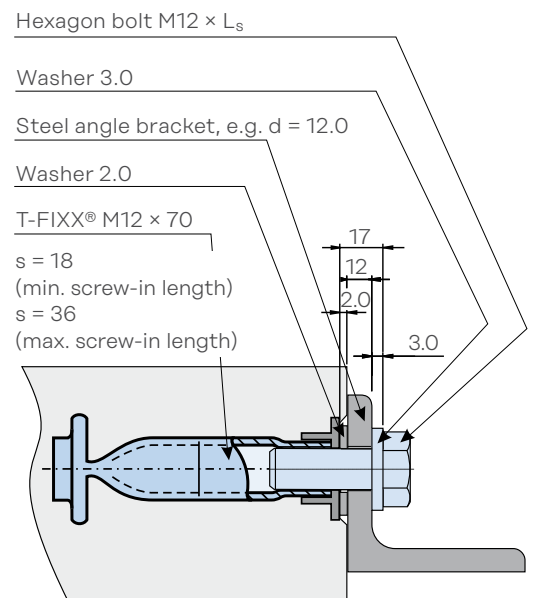
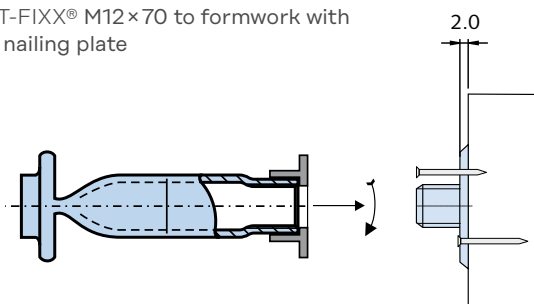

all dimensions in [mm]

Halfen Demu fixing anchor

Calculation Software

General

The following information is required to verify a fixing anchor:

- type and material of the selected Demu Fixing anchor
- size of Demu Fixing anchor (M-thread and length)
- number of fixings (single anchor or groups up to 8 anchors)
- position of the Demu Fixing anchors in the concrete, determined by its distance from the lower, the upper, the left and right edges of the components
- thickness of the concrete component
- concrete strength class
- condition of the concrete, cracked or verified as non-cracked
- (dense) reinforcement in the vicinity of the fixing anchor (yes/no)
- tensile load, shear load and bending, torsional moments



Technical support

We can provide additional engineering services and technical support for your individual projects. Contact information can be found on the back cover.

Verification method

Tension loading

Verify:

- steel failure of fastener
- pull-out failure
- concrete cone failure
- splitting failure
- blow-out failure

Shear loading

Verify:

- steel failure of fastener (with or without lever arm)
- concrete pry-out failure
- concrete edge failure

Verify combination of tension and shear loading



The fixing components (fastening bolts, washers, etc.) are not included with the Halfen Demu Fixing system. These components must be ordered separately for each project in accordance with the static engineer's specifications.

Software download



Note:

A user-friendly, free to use software to simplify calculation can be downloaded at:
www.leviat.com

Halfen Demu fixing anchor

Calculation Software

Leviat Software for fixing anchors

Our calculation program for Demu T-FIXX® and Demu Bolt anchors (types 1988, 1985, 1980-P) provides the user with a convenient and powerful calculation tool.

Basis for the calculation of Halfen Demu Fixing anchors is the European standard EN/TS 1992-4 which also covers the design method for bolt head. This standard prescribes a wider range of verifications, which are processed by our easy-to-use calculation Software. Within a short time the user gets the result for their relevant load situation.

Boundary conditions

The calculation takes into account all necessary boundary conditions, for example:

- concrete strength class
- cracked or non-cracked concrete
- the concrete components geometry, in particular the distances of the fixing anchors to the component edges
- geometry / size of secondary components
- quality of the fixing bolt
- various reinforcement layouts
- consideration of several design loads
- configuration of fixings, e.g. single fastener or groups of fasteners (up to 8 fasteners)

Input

The geometry and loads are entered interactively. Entries are shown in a graphic-display. The anchor geometry can also be modified directly on screen by editing the dimensions or using a mouse.

Calculation

The calculation is in accordance with European standard CEN/TS 1992-4.

Results

The software calculates and displays either the results for a preselected anchor or — in cases of multiple design calculations — a list of all suitable anchors in a list. Results highlighted in red indicate excessive loads or incomplete verifications.



Screenshot 1: start screen



Screenshot 2: programme interface

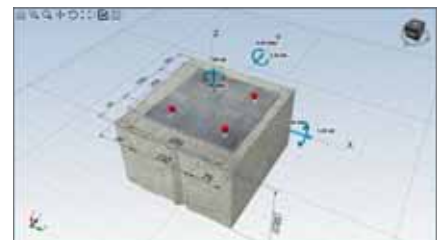

Screenshot 3: graphic representation



Screenshot 4: preview of the end result with calculation

www.halfen.com ► downloads
► software-cad-bim

Halfen Demu fixing anchor

Calculation Software / Tender Text

Leviat Software for fixing anchors



Visual control

All verifications for the selected anchor are listed in the results overview. Values highlighted in red indicate an excessive load. (utilisation ratio higher than 100%).

A click of the mouse and detailed information of all calculation results can be displayed in a detailed report.



Printouts

Printouts are possible in a brief and verifiable long version. The short version shows only an overview of boundary conditions and calculation results of the different failure types.

The long version includes all decisive verifications for a verifiable printout. Both printout versions can be exported as .xps files.



Software version

The latest version of the design software is available for download on the internet at www.halfen.com.

Includes the option to select English, German, French or Dutch as language.

System requirements:

- Windows 8, 10, 11 with up-to-date Servicepacks
- Installed .NET Framework 4.7.2
- Screen resolution: 1024 × 768 px

Tender text

Halfen Demu Fixing anchor type T-FIXX® M16 × 100 GV

Halfen Demu Fixing anchor T-FIXX® with standard metric ISO thread for permanent fixing of components,

with European Technical Assessment ETA-13/0222, suitable for anchoring in reinforced or non-reinforced standard concrete in strength class of at least C20/25 and maximum C90/105 in accordance with EN 206:2017-01, statics proven in accordance with EN1992-4 section 1 and 2,

Type T-FIXX® M16 × 100 GV

with

M16= Standard metric ISO thread size M16 [mm],
100= Total length of fixing anchor [mm] (plus identification clip length),
GV= Corrosion protection zinc galvanized,

or equivalent, deliver and install in accordance with the manufacturer's instructions.



Halfen Demu fixing anchor

Calculation Software / Calculation Example

Example using Leviat Calculation software for T-FIXX®

Installation data

- corrosion protection: zinc galvanized
- concrete: C30/37, gerissen
- slab thickness: $h = 200\text{ mm}$
- concrete cover $c_{nom} = 30\text{ mm}$
- design loads $N_{Ed,z} = 6.0\text{ kN}$
 $V_{Ed,x} = 3.0\text{ kN}$
 $M_{Ed,y} = 5.0\text{ kNm}$
 $M_{Ed,T} = 2.0\text{ kNm}$

- group of four fasteners
- no influence of edges
- strength grade of the fixing bolt is 8.8



Calculation for a selected T-FIXX® M12×70 GV

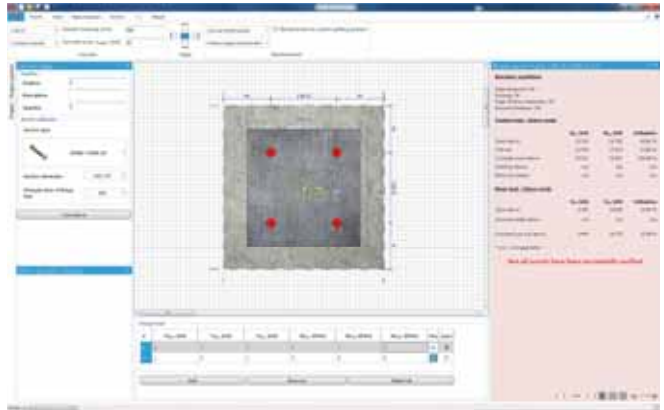

Calculation is negative!

Loads are too high for 4×T-FIXX® M12×70 GV



Results according to EN1992-1-1

Boundary conditions
 Edge distances: OK
 Spacing: OK
 Edge distance baseplate: OK
 Element thickness: OK

Tension load - failure mode

	N_{Ed} [kN]	N_{Rk} [kN]	Utilisation
Steel failure	15.581	18.782	82.85 %
Pull-out	15.581	27.923	55.80 %
Concrete cone failure	33.971	32.947	102.94 %
Splitting failure	n/a	n/a	n/a
Blow-out failure	n/a	n/a	n/a

Shear load - failure mode

	V_{Ed} [kN]	V_{Rk} [kN]	Utilisation
Steel failure	5.446	10.000	54.00 %
Concrete edge failure	n/a	n/a	n/a
Concrete pry-out failure	5.446	26.773	20.34 %

* n/a = not applicable

Not all proofs have been successfully verified.



Solution:
 Start calculation "Multiple design" and apply T-FIXX® M16 x 100 GV

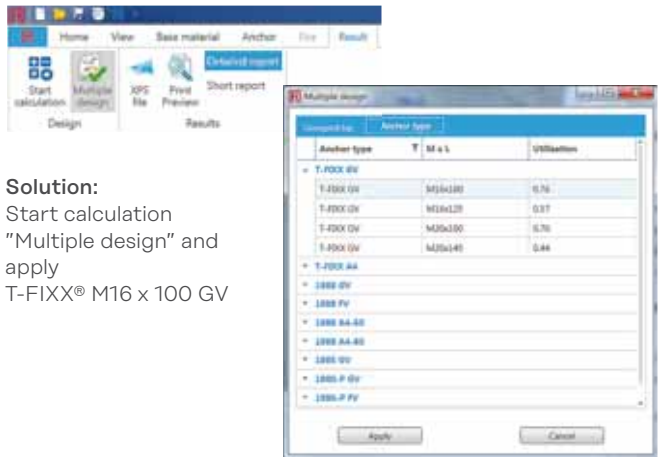

Results according to EN1992-1-1

Boundary conditions
 Edge distances: OK
 Spacing: OK
 Edge distance baseplate: OK
 Element thickness: OK

Tension load - failure mode

	N_{Ed} [kN]	N_{Rk} [kN]	Utilisation
Steel failure	15.932	27.241	58.48 %
Pull-out	15.932	45.683	34.88 %
Concrete cone failure	33.139	47.801	69.37 %
Splitting failure	n/a	n/a	n/a
Blow-out failure	n/a	n/a	n/a

Shear load - failure mode

	V_{Ed} [kN]	V_{Rk} [kN]	Utilisation
Steel failure	5.446	16.345	33.32 %
Concrete edge failure	n/a	n/a	n/a
Concrete pry-out failure	5.446	35.162	15.49 %

Combined tension and shear load

	β_s	β_v	Utilisation
Interaction	0.694	0.333	77.01 %

* n/a = not applicable

All verifications are satisfied.

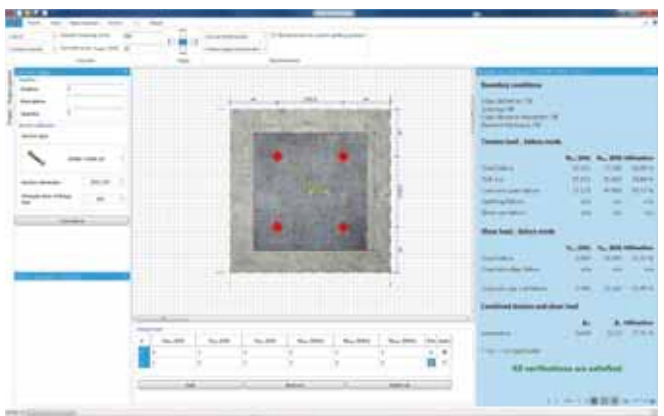

Calculation is positive with 4×T-FIXX® M16×100 GV





Project: Sonnwendviertel SMART-Wohnen
Location: Residential project Alfred-Adler-Straße, Wien
GEISWINKLER & GEISWINKLER Architekten ZT GmbH



Leviat®

Innovative engineered products
and construction solutions that
allow the industry to build safer,
stronger and faster.



Contact Leviat worldwide

Australia

98 Kurrajong Avenue,
Mount Druitt, Sydney, NSW 2770
Tel: +61 - 2 8808 3100
Email: info.au@leviat.com

Austria

Leonard-Bernstein-Str. 10
Saturn Tower, 1220 Wien
Tel: +43 - 1 - 259 6770
Email: info.at@leviat.com

Belgium

Industrielaan 2
1740 Ternat
Tel: +32 - 2 - 582 29 45
Email: info.be@leviat.com

China

Room 601 Tower D,
Vantone Centre
No. A6 Chao Yang Men Wai Street
Chaoyang District
Beijing P.R. China 100020
Tel: +86 - 10 5907 3200
Email: info.cn@leviat.com

Czech Republic

Pekařská 695/10a
155 00 Praha 5
Tel: +420 - 311 - 690 060
Email: info.cz@leviat.com

Finland

Vädursgatan 5
412 50 Göteborg / Sweden
Tel: +358 (0)10 6338781
Email: info.fi@leviat.com

France

6, Rue de Cabanis
31240 L'Union
Tel: +33 (0)5 34 25 54 82
Email: info.fr@leviat.com

Germany

Liebigstrasse 14
40764 Langenfeld
Tel: +49 - 2173 - 970 - 0
Email: info.de@leviat.com

India

Unit S4, 902, A Wing,
Lodha iThink Techno Campus Building,
Panchpakhadi, Pokharan Road 2,
Thane, 400606
Tel: +91-022 695 33700
Email: info.in@leviat.com

Italy

Via F.lli Bronzetti 28
24124 Bergamo
Tel: +39 - 035 - 0760711
Email: info.it@leviat.com

Malaysia

28 Jalan Anggerik Mokara 31/59
Kota Kemuning,
40460 Shah Alam Selangor
Tel: +603 - 5122 4182
Email: info.my@leviat.com

Netherlands

Oostermaat 3
7623 CS Borne
Tel: +31 - 74 - 267 14 49
Email: info.nl@leviat.com

New Zealand

2/19 Nuttall Drive, Hillsborough,
Christchurch 8022
Tel: +64 - 3 376 5205
Email: info.nz@leviat.com

Norway

Vestre Svanholmen 5
4313 Sandnes
Tel: +47 - 51 82 34 00
Email: info.no@leviat.com

Philippines

27F Office A, Podium West Tower,
12 ADB Avenue, Ortigas Center
Mandaluyong City, 1550
Tel: +63 - 2 7957 6381
Email: info.ph@leviat.com

Poland

Ul. Obornicka 287
60-691 Poznań
Tel: +48 - 61 - 622 14 14
Email: info.pl@leviat.com

Singapore

10 Benoi Sector,
Singapore 629845
Tel: +65 - 6266 6802
Email: info.sg@leviat.com

Spain

Polígono Industrial Santa Ana
c/ Ignacio Zuloaga, 20
28522 Rivas-Vaciamadrid
Tel: +34 - 91 632 18 40
Email: info.es@leviat.com

Sweden

Vädursgatan 5
412 50 Göteborg
Tel: +46 - 31 - 98 58 00
Email: info.se@leviat.com

Switzerland

Grenzstrasse 24
3250 Lyss
Tel: +41 (0)800 22 66 00
Email: info.ch@leviat.com

United Arab Emirates

RA08 TB02, PO Box 17225
JAFZA, Jebel Ali, Dubai
Tel: +971 (0)4 883 4346
Email: info.ae@leviat.com

United Kingdom

President Way,
President Park,
Sheffield S4 7UR
Tel: +44 - 114 275 5224
Email: info.uk@leviat.com

USA / Canada

6467 S Falkenburg Road
Riverview, FL 33578
Tel: (800) 423-9140
Email: info.us@leviat.us

For countries not listed
Email: info@leviat.com

Notes regarding this document

© Protected by copyright. The information in this publication is based on state-of-the-art technology at the time of publication. In every case, project working details should be entrusted to appropriately qualified and experienced persons. Leviat shall not accept liability for the accuracy of the information in this document or for any printing errors. We reserve the right to make technical and design changes at any time. With a policy of continuous product development, Leviat reserves the right to modify product design and specification at any time.

