

JORDAHL[®] Elevator insulation JAI

Technical information



Table of contents

Foreword	4	Elevator insulation JAI as a system solution	13	Planning information	18
PohlCon synergy concept	4	System solution with anchor channel JTA	13	Sound insulation in elevator construction	18
An overview of the system	6	System solution with other fastening elements	13	Basic principles and standards	19
Elevator insulation JAI	9	Elevator insulation JAI in use	14	Sound insulation with elevator insulation JAI	21
Technical qualification	9	References	15	Elevator insulation JAI in the test laboratory	22
Type overview	10	Lokstedter Steindamm	15	Cost-effectiveness calculation	23
Technical data	11	Installation instructions	16	Service	26
JAI-A load deformation curves	12			Our synergy concept for you	26

Our synergy concept for easy construction.



Three brands, one point of contact.

PohlCon combines the product portfolios and expertise of long-established companies PUK, JORDAHL and H-BAU Technik. As a customer, you benefit from the convenience of having a central point of contact, which will help you to plan, build and fit out your building.

The phrase "That's not possible" is simply not part of our vocabulary. We have a can-do attitude and we will always find a way. However large or unusual your construction project, we can provide exactly the right parts for your needs. Our made-to-measure products are perfectly tailored to your requirements.

When it comes to construction, we lighten the load.

As a central point of contact for the different trades and construction phases, we are here to find the right solution for you; we work with you from the beginning to plan it and provide ongoing support when it comes to actually using it.

Combined product portfolio – extensive expertise – over 200 years' combined experience in the construction industry.



PUK Group GmbH & Co. KG

Our cable management system and underfloor system experts offer efficient building service equipment installation and future-proof solutions.



JORDAHL GmbH

Inventors of the anchor channel and experts in reliable reinforcement, fastening and connection solutions for innovative architecture.



H-BAU Technik GmbH

Experts in sealing, thermal insulation, formwork, sound insulation and reinforcement solutions.

10 Product categories

Find the right product faster

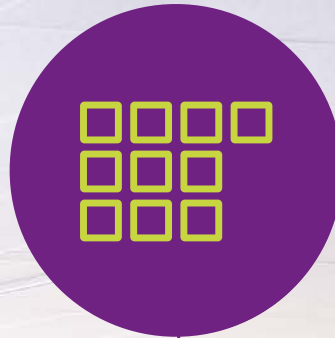

7 Applications

Take a holistic approach to solutions



Bespoke solutions

Overcome exceptional challenges and bring unique construction projects to life



Digital solutions: Software and BIM data

Enjoy tailored support for your planning process



Full service, from planning through to use

Benefit from ongoing direct support, from the planning phase all the way through to use

An overview of the system

Elevator insulation JAI from JORDAHL is used for acoustic decoupling of elevators. Elevator insulation JAI acts in the same way as a spring-mass system and is fitted between the elevator guide rail and the concrete wall.

Without elevator insulation JAI, a structure-borne sound bridge is formed where the guide rail is coupled to the shaft wall. The structure-borne sound transmitted along this sound bridge is transferred directly from the elevator to adjacent rooms, where it is then emitted as airborne sound. This can result in unwanted noise with a lasting negative impact on the comfort of those living in affected rooms.

Elevator insulation JAI is therefore designed to reduce structure-borne sound at the most effective point in the shaft.

Its narrow design consists mainly of insulating panels and steel plates assembled with special T-bolts by JORDAHL. This enables elevator insulation JAI to be used in the majority of elevator systems.

Application area

Elevator insulation JAI is suitable for all projects where sound insulation is a factor. The hotel industry, hospitals, care homes and high-value residential complexes, where great care is taken to ensure the best possible sound insulation, are all examples of applications for sound insulation JAI.

Elevator construction

- Decoupling the attachment points on the shaft wall
- Primarily on the mounting of the guide rail
- Special solution also suitable for use in the shaft head and near to the elevator drive
- Suitable for both new and existing systems in residential, industrial and office buildings

Additional applications for wood construction and power plant construction are currently in the planning stage.







Elevator insulation JAI

The TÜV-certified elevator insulation JAI by JORDAHL is used for acoustic decoupling of elevators, reducing the induced structure-borne sound by up to 26 dB at the transition point between the elevator guide rail and the shaft wall.

Product description

The system consists of sandwich-layered insulating elastomeric plates and a support structure consisting of steel inserts and special T-bolts, primarily fitted to the JORDAHL anchor channel JTA. The standard add-on part of the elevator manufacturer is used to connect the elevator guide rail to the JAI element. Once the JAI element has been properly installed, the attachment part is almost completely insulated. This means that the elevator is decoupled from the structure and transmission of sound is reduced at the most effective point, enabling the elevator insulation to meet high sound insulation requirements.

The load-bearing capacity of the elevator insulation is a particularly important feature, enabling it to be described as a load-bearing insulation element for a wide range of applications.

Technical qualification

Elevator insulation JAI is certified by TÜV (Technical Inspection Authority in Germany) with voluntary type testing in accordance with 2014/33/EU, 2006/42/EC, EN 81-20:2014, EN 81-50:2014.

This was demonstrated on 26.11.2019 by means of a conformity test.

The test specifications were in accordance with test report no.: 01/208/FB19/7077:

- Directive 2014/33/EU (Lift Directive)
- Directive 2006/42/EC (Machinery Directive)



Advantages

- Airborne sound reduction of up to 12 dB in adjacent rooms
- Suitable for elevator systems in new and existing structures: centrally guided, backpack suspension or freight elevators, e.g. for passenger cars
- Increased process reliability for elevator sound insulation planning
- Low-maintenance, easy-to-install system solution with the tried-and-tested anchor channel JTA
- Customisable for use with almost any add-on part/bracket from elevator manufacturers
- Project-specific solutions available on request



Type overview



JAI-A

Elevator insulation JAI-A is often used in centrally guided elevator systems. The JAI-A1 variant and the adjustable JAI-A1J variant are available with a round hole or a slotted hole connection to ensure maximum flexibility during assembly.



JAI-R

The elevator insulation JAI-R has been specially designed for elevator shafts that require a rucksack suspension due to limited space available. It combines the design adaptations for parallel guide rails with the benefits of the familiar TÜV-certified JAI-A.



JAI-L

The JAI-L type, which is based on the JAI-A type, provides an option for acoustic isolation of freight elevator systems. This is particularly in demand for elevator systems with high load-bearing capacities used for overcoming different storeys in buildings, for adding new storeys to existing buildings or for integrating car parking spaces into existing buildings.

Technical data

Element	Height mm	Width mm	Depth mm
JAI-A1*	120	192	42.0
JAI-A1J*	120	192	63.0
JAI-R1*	120	280	57.5**
JAI-L1*	192	250	47.0

* Dimensions differ for dowel solutions

** The length of the elevator insulation JAI together with the L-shaped bracket is 324.5 mm.

Standardised transmission insulation index, frequency averaged in x-, y- and z-direction*



Direction	63 Hz	125 Hz	250 Hz	500 Hz	Average from FFT**	Average from octave
x-axis	26 dB	24 dB	23 dB	22 dB	22 dB	24 dB
y-axis	20 dB	21 dB	20 dB	18 dB	19 dB	20 dB
z-axis	14 dB	13 dB	12 dB	11 dB	12 dB	13 dB
Average of x, y, z	20 dB	19 dB	18 dB	17 dB	18 dB	19 dB

* Based on the types JAI-AI and JAI-AIJ

** Fast Fourier transform (mathematical evaluation function)

Material and surface coating

The elevator insulation is available in the following variants:

-  Galvanised steel
-  Stainless steel (on request)

In both variants, the insulation material consists of:

-  Mixed cell polyurethane



Tender texts available
on request

JAI-A load deformation curves

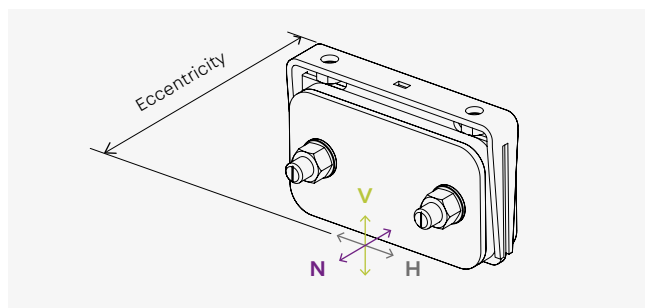
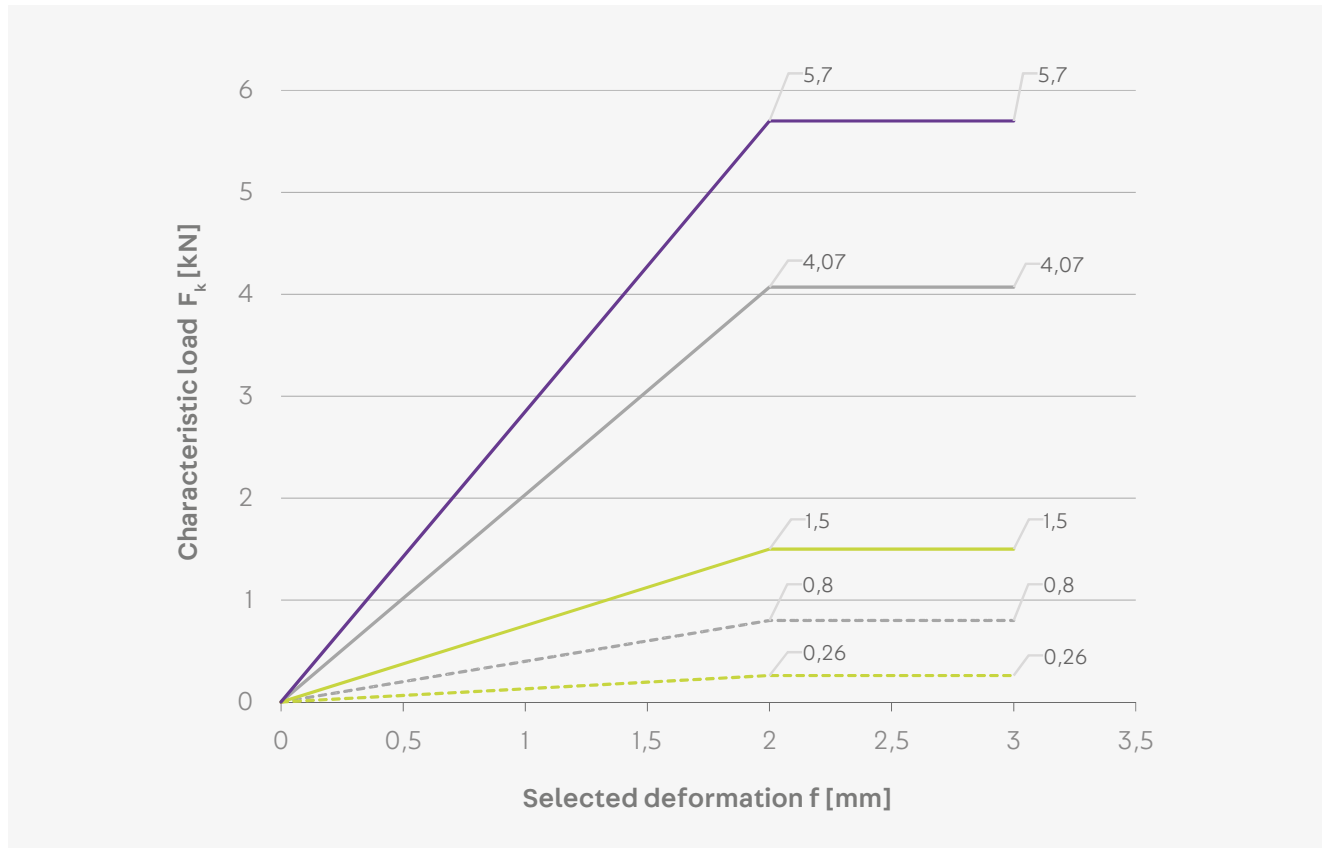

- N - not dependent on lever arm
- H - short lever arm / 125 mm
- - - H - long lever arm / 325 mm
- V - short lever arm / 125 mm
- - - V - long lever arm / 325 mm

As part of the load testing, load deformation curves were also determined for the elevator insulation JAI, specifying the load-bearing capacity and extent of deformation, making product design as easy as possible for planners.

The data in the diagram is based on internal load tests monitored by TÜV and is incorporated into the planning process. The properties of the sound absorbing insulation plates are particularly important for the durability and performance of the elevator insulation JAI.

They meet the requirements for long-term, qualified use, as has been demonstrated over a wide variety of tests. The range of applications and associated boundary conditions can be found in the operating instructions for the elevator insulation JAI.

Elevator insulation JAI as a system solution

System solution with anchor channel JTA

The elevator insulation JAI reaches the full extent of its potential when used as a sound insulation solution in combination with anchor channels JTA by JORDAHL. For new systems in particular, anchor channels can be planned in advance for installation of the elevator insulation JAI in the elevator shaft.



JTA W 40/22 and W 50/30 anchor channel by JORDAHL
Anchor channel made of hot-rolled steel for maximum stability.



JB and JC hook-head T-bolts by JORDAHL
Special T-bolt for an interlocking connection with anchor channels.



System solution with JTA anchor channel
Combination of elevator insulation JAI with special T-bolts and anchor channel JTA W.

System solution with other fastening elements



JM W mounting channel by JORDAHL
The hot-rolled mounting channel JM W is suitable for bearing tensile and shear loads.



JB and JC hook-head T-bolts by JORDAHL
Special T-bolt for an interlocking connection with mounting channels.



Modification of the JAI types to create dowel variant
If it is not possible to secure the JAI elements to anchor channels, custom-designed dowel variants of the elevator insulation JAI can be used. The JAI element is pre-fitted on a dowel plate and then fixed in the shaft with dowels.

Elevator insulation JAI in use

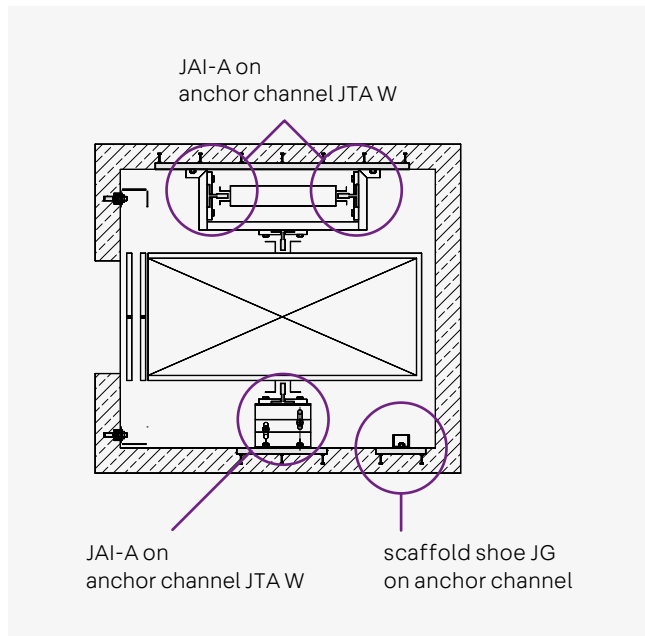

Schematic arrangement of the anchor channels JTA W with elevator insulation JAI by JORDAHL

The arrangement and number of JAI elements is determined for every application. A commonly used variant for centrally guided elevator systems is arranging two JAI elements on the counterweight side and one additional element on the elevator car side per level.

The JAI elements can also be used in steel shaft frames. In this case, we recommend using them in conjunction with our mounting channels.

Leading experts state that expectations regarding elevator passenger comfort are increasing, while at the same time elevator shafts are becoming increasingly narrow and shaft heads and pits are becoming increasingly short. These constraints have a significant effect on sound insulation goals. As a result, sound insulation in elevator systems is becoming increasingly complex.

Customers often come to us seeking solutions for these issues. In response, we have already successfully developed customer-specific special solutions for new and existing systems. These solutions are suitable for extreme space constraints in the shaft as well as for fastening points in the shaft head. Following a consultation, we can configure custom solutions for almost all conventional elevator systems.

The following data is used for developing a customer-specific solution:

- Shaft/system drawing
- Rail forces $f(x)$ and $f(y)$
- Type of fastening
- Lever arm or space from the wall

However, there are different requirements for elevator construction in the context of modernisation projects. When working with existing shafts, there is no opportunity to change the building structure. Any sound insulation measures can only be implemented within the system itself. If subsequent measurements indicate that the agreed-upon sound insulation goals have not been met, the level of effort and expenditure required to meet the required values is significantly higher. If our elevator insulation JAI is to be retrofitted in a shaft, we recommend using our modernisation solutions with mounting channels or for dowel mounting.



Our technical consultation team is happy to help you with detailed planning of a construction project.

T +49 (0) 30 68283-02
contact@pohlcon.com

References

The performance of JAI elements has been consistently demonstrated in a variety of environments in collaboration with a various testing institutes and measurement bureaus. At the Fraunhofer Institute for Machine Tools and Forming Technology (IWU), elevator insulation JAI by JORDAHL underwent a variety of sound insulation tests with positive results. These

results have been confirmed by further testing by independent experts in the relevant elevator systems. An example of the flexibility of elevator insulation JAI is provided in greater detail below. We are happy to provide you with information about additional reference projects upon request.

Lokstedter Steindamm

System in new building

A number of reference construction projects were completed in order to be able to test the IWU results in practice. In the "Lokstedter Steindamm" project in Hamburg, sound level measurements were taken from the installed elevators with and without elevator insulation JAI and then evaluated.

The JAI elements were fitted to the elevator shaft walls for insulation of structure-borne sound (see pictures below). To determine their effectiveness, several measurements were taken from a single elevator system. The measurements were taken during operation of the same elevator system in an utility room on the first floor directly adjacent to the elevator shaft. The elevator shaft wall (reinforced concrete) had a thickness of 30 cm. With a density of 2300 kg/m³, this corresponds to an area density of 690 kg/m².

This project referred to an elevator system intended for installation in an area with high sound insulation requirements. With a wall thickness of 30 cm (690 kg/m²), the elevator shaft meets the required design specifications in accordance with DIN 8989 Table 3. The mounting of the elevator unit and the bearings for the traverse can also be described as high-quality.

Due to the high requirements laid down for sound insulation, it can be assumed that the requirements for the elevator system in accordance with Table 4 of DIN 8989 have also been met.

The standard sound pressure level relevant for the assessment of measurements with no structure-borne sound insulation was 32.2 dB(A). Compliance with the required standard criteria was monitored throughout the entire process. The fact that there was nevertheless a high level of airborne noise level in the adjacent room was therefore able to be traced back to the effects of structure-borne sound. The standard sound pressure level relevant for the assessment of measurements with elevator insulation JAI from JORDAHL was 20.1 dB(A). This means that the JAI elements resulted in less structure-borne sound being transferred to the 30 cm-thick elevator shaft wall and emitted into the rooms as airborne sound. As a result, the standard sound pressure level in an immediately adjacent room was $L_{AFmax,n} < 20$ dB(A).

With the standard sound pressure level in the utility room of $L_{AFmax,n} = 20$ dB(A), it is also possible to place a bedroom in this location. The sound pressure level here is approx. 4 dB below the sound insulation target in accordance with DIN 8989 of $L_{AFmax,nT} \leq 24$ dB(A). The use of elevator insulation JAI reduced the airborne sound by 12 dB(A). The practical test at the Lokstedter Steindamm location also confirmed that the sound insulation performance of elevator insulation JAI recorded in the laboratory was able to be reproduced in practice as well. It also demonstrates that the elevator insulation is highly beneficial for ensuring building design that meets sound insulation targets, even in the case of high-quality elevator shafts and elevators.



Installation instructions

Easy to install in new structures and modernised systems
in existing structures

To ensure proper use of the elevator insulation JAI by JORDAHL, it is important to consult the operating instructions, incl. assembly instructions. These instructions contain safety information that must be complied with. They also provide storage instructions that are relevant for intermediate transport or long storage periods.

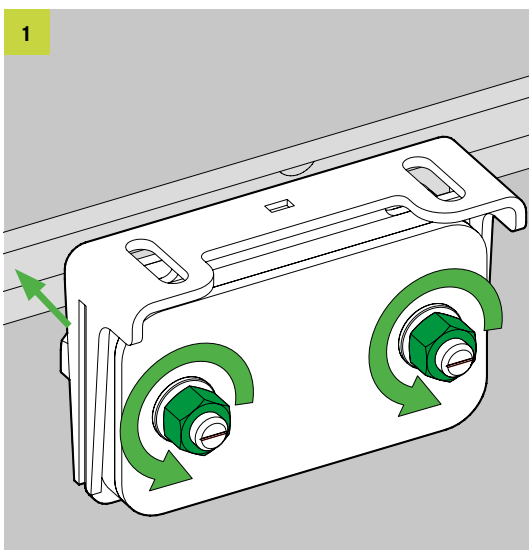

Before using the JAI element, the T-bolts should be loosened (not completely screwed down) to enable them to be attached to the mounting surface.

Once the JAI has been positioned, the element together with the hook-head T-bolts can be inserted into the anchor channel. The exact position for subsequently attaching the guide rails must then be determined. The JAI element must be fixed in place accordingly. It is important to make sure that the T-bolts are secured.

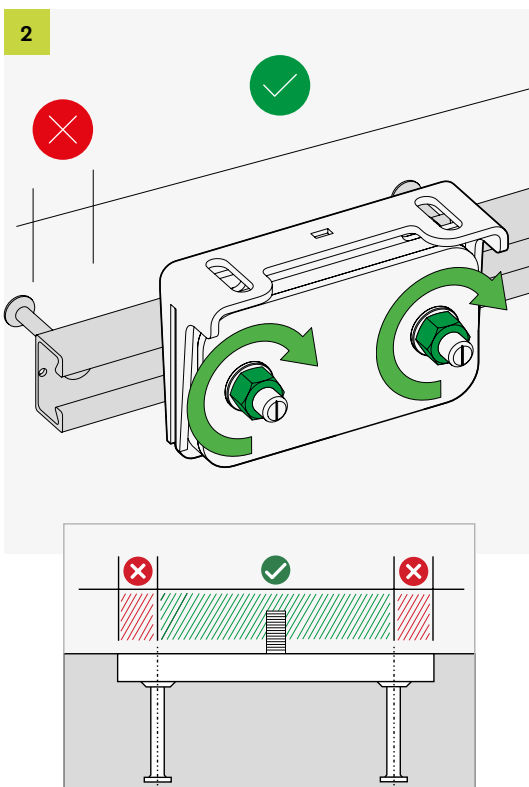

To do so, the T-bolts are first manually tightened and stabilised in place so that the position is fixed. When doing so, it is important to ensure that the elevator insulation JAI is sufficiently far from the edge of the anchor channel JTA, meaning that it is not fitted behind the rear anchor or in front of the first anchor (the so-called anchor channel overhang). Alternatively, the elevator insulation JAI can be fitted to a mounting channel JM.

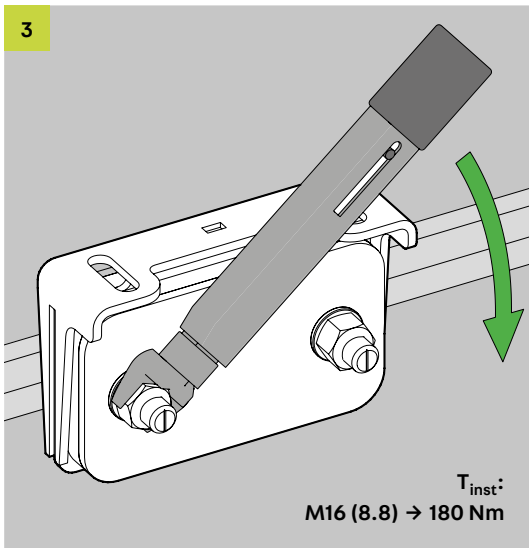

Elevator insulation JAI must be fixed in place with the correct tightening torque to enable load transfer to take place. It is important to use the correct tools, such as a calibrated torque wrench or similar, to ensure this.

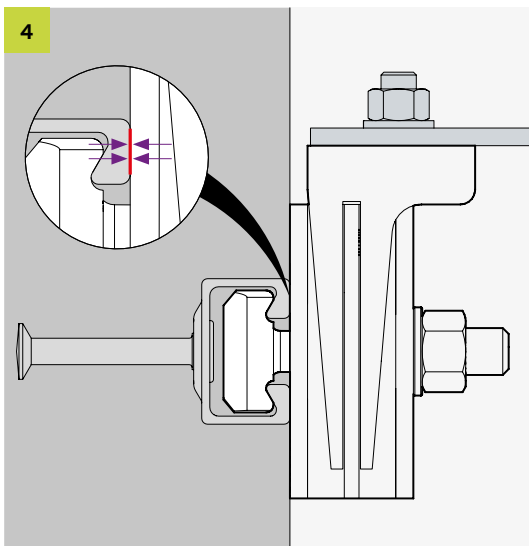

Important: When installing elevator insulation JAI, the connection between the JAI element and the anchor channel must be secured via a steel-to-steel contact in order to ensure that transmission of force is permanently guaranteed. For this reason, prior to starting assembly of the JAI element, it is vital to check that the anchor channels are installed flush and in the correct position. If this is not the case, compensating measures must be implemented.

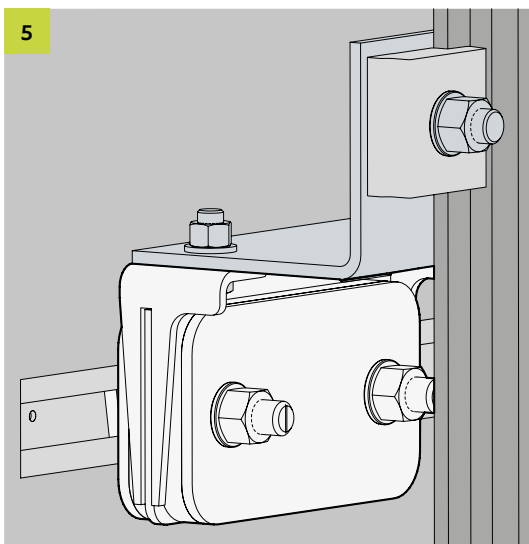

The guide rails of the elevator are to be affixed to the JAI element via a steel bracket. The bolt connection is positioned at the top support point on the steel core of the elevator insulation JAI. The geometric constraints at the attachment point must be taken into account.

Planning information

Sound insulation in elevator construction

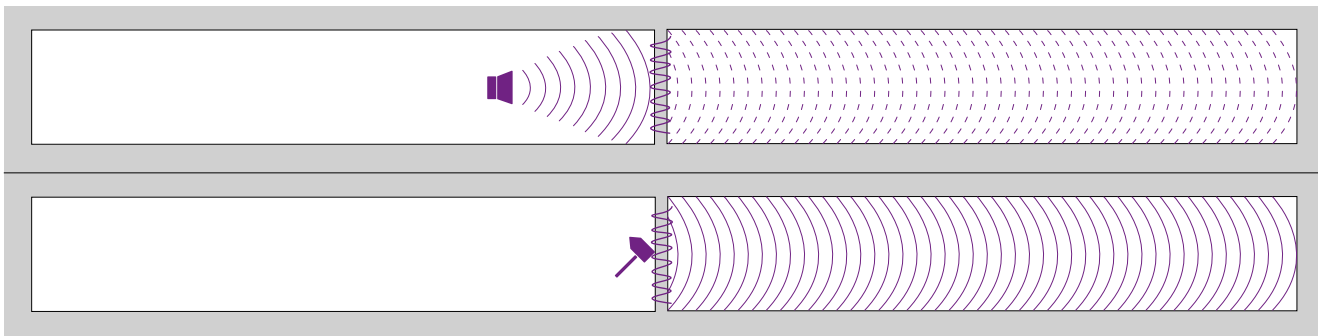

Connection between airborne sound and structure-borne sound

Sound spreads not only through the air, but also in solid objects. When airborne sound waves hit a wall, the majority will be reflected. However, sufficiently strong vibrations will cause the wall itself to vibrate as well. For example, a loud music system in a room can cause structure-borne sound vibrations in a wall. This means that a portion of the airborne sound waves produced by the music system will propagate through the solid structure of the wall.

The airborne sound has therefore been converted into structure-borne sound. Thus, there is an indirect connection between airborne sound and structure-borne sound. The proportion of sound that is emitted from the sound source and transmitted through the air is referred to as airborne sound. The solid object, in this case the wall, acts as a kind of loudspeaker and amplifier for the sound.

If the sound propagates in a solid object and is perceived by the sense of touch, this is structure-borne sound. This kind of sound can only be prevented by decoupling the structural components. Structure-borne sound in a wall – or in other solid objects – does not necessarily result from the conversion of loud airborne sound sources. It can also occur as a result of direct forces acting on the solid object, for example by hammering a nail into a wall.

The same principle applies for structure-borne sound occurring in elevator spaces. The vibrations of the elevator are transferred to the wall via the guide rail. In order for these vibrations to be perceived as noise by the human ear, the structure-borne sound must then be converted into airborne sound.

This happens when the structure-borne sound is transmitted by walls, floors or other solid objects. These objects consequently become vibrating sound sources that cause the nearby air molecules to move. In this way, the sound source

penetrates through the wall into the adjacent apartment and ultimately reaches the ears of inhabitants.

Elevators constantly emit airborne sound and structure-borne sound while they are in operation. As a result, the planning process for sound insulation as part of elevator systems always requires close collaboration between the elevator manufacturer and the building planner or structural specialist planner.

As a general rule, the transmission of structure-borne sound that is in turn emitted into the air is the most important factor determining whether elevator noise is perceived in rooms in need of protection. Structure-borne sound is transmitted into the building itself at all points where the elevator is in contact with the building. If the noise of the lift is perceived as a nuisance, this constitutes unwanted noise. The primary factor determining how disruptive the noise is for inhabitants is its volume, which in turn depends on the design of the elevator shaft and the elevator type.

The DIN 8989 standard contains recommendations for achieving the required sound insulation in rooms in need of protection, which primarily consist of structural measures for the elevator shaft or the machine room. The DIN 4109 standard specifies minimum requirements for sound insulation. If a higher level of sound insulation is desired for a project, this must be contractually agreed upon.

Sound insulation should be taken into account from the start of the planning process onwards, and should be incorporated into the floor plan design and the arrangement of structural components and systems. Components that make it easier to comply with the required level of sound insulation or that help to provide a higher level of process reliability for sound insulation levels should likewise be carefully considered during the planning phase.

Basic principles and standards

Numerous important standards are applicable for the planning and implementation of elevator construction projects. Contracts for work drawn up on the basis of the German Construction Tendering and Contract Regulations (Vergabe- und Vertragsordnung für Bauleistungen, VOB) or the German Civil Code (Bürgerliches Gesetzbuch, BGB) serve as the basis for developers.

In addition to the structural design safety principles for elevators and process-relevant safety regulations for structural components, there are many provisions that regulate structural sound insulation. The operation of an elevator produces noise that propagates from the elevator shaft as sound in a variety of forms. Depending on the building design, elevator type and geometric parameters, sound can propagate into adjacent rooms in different ways and be perceived as a nuisance. With insufficient planning or improper implementation, this can have a substantial negative impact on living comfort.

Overview of EN 81-20/50

A new European standard for elevators entered into force on 1st September 2017. The abbreviation EN 81-20/50 actually stands for two standards: DIN EN 81-20 and DIN EN 81-50.

EN 81-20 defines the specifications for the design and technical properties of elevators. It also stipulates the parameters to be observed when installing elevators. By contrast, EN 81-50 specifies how tests should be performed on components and elevators. In addition, the specifications of the Machinery Directive 2006/42/EC and the European directive 2014/33/EU on the harmonisation of the laws of the member states relating to lifts and safety components for lifts must be complied with. Safety, for example with regard to safety specifications for construction, operation and maintenance of elevators, plays a central role here.

Overview of DIN 4109-1

DIN 4109-1 describes the basis for requirements and analysis regarding structural sound insulation. Since the building code always starts out from the "principle of least intervention" according to the "principle of proportionality", this DIN standard merely contains (minimum) requirements under public law for sound insulation to prevent health hazards. If the principles and implementation instructions listed in this standard are observed, it can be assumed that the minimum sound insulation requirements stipulated by the building code have been complied with.

Overview of VDI guideline 4100

For many planners and building developers, however, the minimum sound protection values are insufficient. Back in 1994, the Association of German Engineers published the VDI 4100 guideline – Sound insulation in buildings – Criteria for planning and assessment, drawn up by the DIN/VDI Standards Committee Acoustics, Noise Control and Vibration Engineering. This guideline defines three sound insulation levels for assessing different qualities of structural sound insulation (sound insulation level I to III). By assigning the sound insulation levels to the usual building assessment levels, the quality of the sound insulation in a home can be defined in building contracts and described as a value-adding property.

Sound insulation level III (SSt III) can be expected for a home which also meets high standards of comfort in its other fittings. More and more planners are using the sound insulation levels laid down in VDI 4100 when planning sound insulation for construction projects. This also applies for planning elevators and rooms that require protection, which was also addressed in VDI 2566.

Sound insulation criterion	Sound pressure level in dB(A)	SSt I/ SSt EB I	SSt II/ SSt EB II	SSt III
Apartment buildings*	$L_{A_{fmax, nT}}$ **	≤ 30	≤ 27	≤ 24
Detached, semi-detached and terraced houses*	$L_{A_{fmax, nT}}$ **	≤ 30	≤ 25	≤ 22

Source: Sound insulation values for sound insulation levels, extract from VDI 4100, 2012

* Building service systems including water supply and sewage systems

** Individual, temporary noise peaks which occur when water installation valves and equipment are operated must not exceed key values SSt II and SSt III by more than 10 dB(A). Intended use is assumed here.

Elevator systems produce noise when switching, starting up, moving and braking, which can be transmitted to rooms that require protection (such as living spaces). If the elevator system and the building as a whole are not properly planned and/or constructed, these elevator systems will cause disruption and nuisance in such rooms. It is of great importance whether the machine room and/or elevator shaft are directly adjacent to living spaces.

Overview of DIN 8989

Sheet 1 of the VDI 2566 standard describes elevator systems with machine rooms, and sheet 2 of the VDI 2566 standard describes elevator systems without machine rooms. It was necessary for the VDI guidelines to be revised in order to describe the requirements for the elevator and the building, or the elevator shaft. These two supplementary sheets were combined in 2018 in the standard DIN 8989 "Acoustical design in buildings – lifts" (published in August 2019), which describes important interdependencies regarding sound insulation in detail. In accordance with DIN 4109, the noise produced by an elevator system in rooms in need of protection must not exceed the following values for the permissible A-rated sound pressure level:

Living spaces and bedrooms: 30 dB

Classrooms and working spaces: 35 dB

These are minimum sound insulation values that are relevant under building law and must be complied with.

Table 3 (Sound emission values to be observed by elevators

to achieve sound insulation targets) and Table 4 (Area-related masses of walls and ceilings to be observed to achieve sound insulation targets) in DIN 8989 are now attracting attention beyond the borders of Germany. Depending on the location of the rooms in need of protection, the correlation between the area-related masses for achieving the sound insulation targets is described. The requirements for elevator systems regarding sound emissions set out in DIN 4109 and/or VDI 4100 are specified accordingly.

In accordance with DIN 8989, the elevator system and the shaft design (area density) have equal parts to play in meeting sound insulation targets. In order to ensure that the sound insulation targets are met, the building contractor and the elevator manufacturer or installation company must coordinate closely with one another to formalise them as a shared objective for their collaboration. Requirements for the elevator system with respect to airborne and structure-borne sound, the location of rooms that require protection and area density of the elevator shaft must be defined in invitations to tender, requirements specifications or building plans. It is no longer sufficient to simply state that the requirements of DIN 4109 or VDI 4100 are to be complied with. DIN 8989 places a higher value on sound insulation for elevator system and the risk of failing to meet the specified values is therefore substantially greater.

Sound insulation with elevator insulation JAI

Elevator insulation JAI helps to ensure that contractual sound insulation targets are met. As a structure-borne sound insulation element, elevator insulation JAI increases the process reliability and efficiency of measures to reduce the sound pressure level in elevator shafts. The most significant problems concerning elevators and building elevator shafts occur if the required sound insulation targets are not met due to inadequate planning. Since such projects involve several disciplines coming together in a single place, and since different construction companies carry out construction of the elevator shaft during the shell construction phase and construction of the elevator system, close coordination is required between the planners, construction companies and elevator installers.

However, it is often the case that, as a result of poor coordination or improper execution, follow-up work is necessary to ensure that the proper sound insulation level is met. Elevator insulation JAI can reduce the effort and expenditure required for such follow-up work, or prevent it entirely if included in planning ahead of time.

Elevator insulation JAI is therefore a high-quality and cost-effective solution with parameters verified by the TÜV. Sound insulation planning that incorporates elevator insulation JAI is more reliable, affording greater planning freedom for everyone involved in the construction project.

The JAI element can be used both in new buildings and in existing buildings. The certification of the product by the TÜV (Technical Inspection Authority in Germany) is based on load testing carried out with anchor channels and hook-head T-bolts. JAI elements are delivered with the appropriate special screws for the anchor channel type installed, JTA W40/22 or JTA W50/30.

The anchoring of the component in the concrete is therefore in accordance with the European Technical Assessment (ETA-09/0338). It is therefore recommended to include the elevator insulation JAI in the planning process as a system solution with the appropriate fastening elements and to pay attention to this already during the tendering process. Elevator insulation JAI can also be used in existing structures and for renovation work.

In both cases, elevator insulation JAI can be attached to the concrete wall of the elevator shaft using different fastening elements (e.g. dowels). In this case, it is recommended to contact the PohlCon technical service for technical advice prior to implementing the selected procedures. Since load transfer primarily occurs via the fastenings, uncertified fastening elements or fastening elements that have not been directly tested together with the JAI element are considered to be a special solution and should be evaluated on a case-by-case basis.

In addition to load transfer, the criteria for serviceability are also important for long-term and functional use of elevator insulation JAI. The dynamic stresses produced by operation of the elevator cause deformations in the guide rails, which must be compensated for to some extent by the elevator insulation JAI.

The guide rails are therefore designed in such a way that the total of the deformation caused by the flexible rail holder and the deflection of the guide rail remains less than the maximum deflection permitted in accordance with EN 81-20. For verification of the guide rail, the permissible deformation according to EN 81-20 is divided between the decoupled rail holder and the guide rail.

Applications of elevator insulation JAI

New buildings (planning)

- to be considered in the tender
- in conjunction with anchor channels
- in conjunction with hook-head T-bolts



System solution (certified)
Approved product

Existing structures

- in an existing elevator shaft with anchor channels
- using other fastening elements, e.g. dowels or mounting channels
- adapting fastening elements to the specific conditions of the concrete subsurface



Special solutions
Technical Service

Elevator insulation JAI in the test laboratory

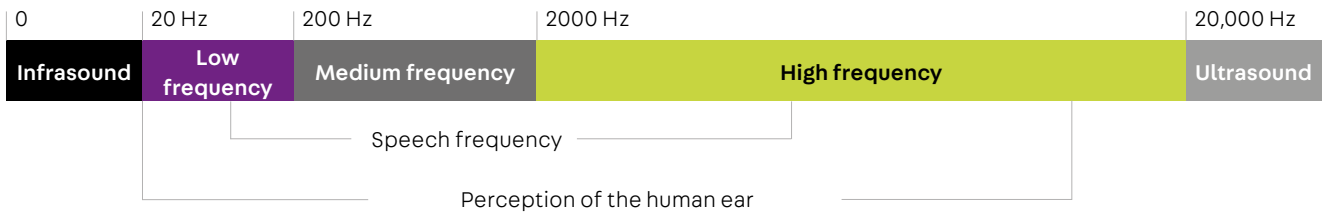

In general, sounds are divided into the following three frequency ranges:

- Infrasound (< 16 Hz) is not audible to humans because the frequency is too low.
- Audible sound (approx. 16 Hz - 20 kHz) is sound that is audible to humans.
- Ultrasound (20 kHz - 1.6 GHz) is not audible to humans because the frequency is too high.

The frequency range of approx. 100 Hz to 200 Hz is a particularly critical range. This is a low-pitch range that is within the audible range for humans and is produced in particular by the acceleration of elevator cars and elevator counterweights. Preliminary studies have shown that a frequency of 125 Hz has the highest potential to cause disruption for inhabitants and is therefore often considered to be unwanted noise.

Accordingly, the sound testing for the elevator insulation JAI at Fraunhofer Institute for Machine Tools and Forming Technology (IWU) focussed primarily on octave band frequencies between 63 and 500 Hz.

In order to analyse the three-dimensional effect of the sound that is applied to the element and can therefore be transmitted by it, the sound reduction index was measured in all three directions.

Depending on the elevator type and the arrangement of the guide rails, the elevator insulation JAI is able to ensure structure-borne sound insulation in all directions.

The z-direction of the standardised transmission insulation index contributes to emission of airborne sound into adjacent rooms. Noise emissions into adjacent rooms are primarily caused by structure-borne sound induced by the elevator, transmitted via the support structure of the building and emitted in the form of airborne sound from ceilings and/or walls. It is therefore important for measurements to be taken in several directions in order to portray the full performance range of the product.

In the tests carried out at the IWU, it was demonstrated that a transmission insulation index of at least 12 dB in the lower performance range and up to 26 dB in the upper performance range can be achieved within the measured frequency range. Depending on the design of the elevator shaft and the elevator type, elevator insulation JAI enables reliable sound insulation. To determine the precise contribution made by the JAI elements, sound level measurements can be taken on site and then evaluated in the overall context of reducing the noise level.

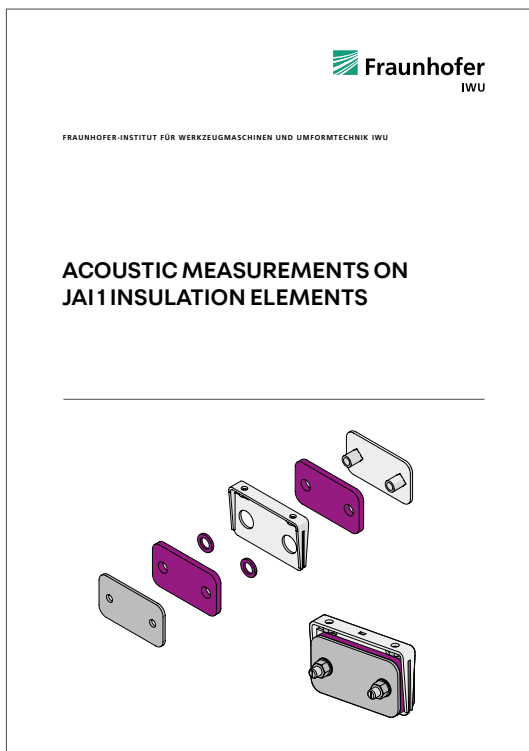

Cost-effectiveness calculation

Elevator insulation JAI installed in a single-layer shaft has at least the same insulating effect as a two-layer shaft design. According to an expert analysis, the benefits of JAI elements are particularly noteworthy in terms of preventing sound bridges forming, spare requirements for buildings and construction costs. The expert concluded that the use of elevator insulation JAI in a single-layer elevator shaft is comparable to the use of a two-layer elevator shaft. Two

example calculations provide more insight here. These demonstrate the cost-effectiveness of the insulation in a standard system installed in a four-storey building situated within a medium-sized town. To highlight the space and cost savings, project-specific calculations can also be carried out.

Evaluation of space requirements

Evaluating the impact of using elevator insulation JAI on space requirements also draws attention to the long-term benefits of using JAI elements in elevator shafts. The example calculation demonstrates that simply increasing the size of the shaft by just 50 mm in comparison to the standard shaft width of 1.60 m provides a space saving of more than 4 m² in comparison to adding a second layer to the plans. This corresponds to substantially more available living space.

The number of residential levels is variable and plays an important role in the analysis, since it also defines the height of the elevator shaft. The regional factor is also incorporated into analysis of the property, as shown in the example calculation - it is crucial to consider whether the building is situated in a small town, in a rural area, in a particularly highly sought-after area or in a large city.

	Unit	Single-layer elevator shaft with JAI	Two-layer elevator shaft without JAI
Basic data			
Clear shaft width	m	1.65	1.65
Clear shaft depth	m	1.75	1.75
Clear shaft height	m	14.90	14.90
Shaft wall thickness	m	0.20	0.20
Insulation layer thickness (for 2-layer shaft)	m	0.00	0.03
2nd layer: Wall thickness	m	0.00	0.20
Basement levels	Pcs	1	1
Residential levels	Pcs	4	4
Area covered (not including plaster)			
Elevator shaft	m ²	4.41	4.41
2nd layer	m ²	0.00	1.14
Area required for elevator (not including plaster)			
Basement level	m ²	4.41	5.55
Residential levels	m ²	17.64	22.20
Difference (residential levels only)	m ²	4.56	



Project-specific calculations can be performed by our technical consultation team upon request.

Evaluation of construction costs

The example calculation shows that the use of JAI elements is calculated as a single expense. By contrast, constructing a second formwork layer involves a range of accounting items that differ for each individual construction project. This calculation takes into account the regional factor, the various

supplier prices and other project-specific stipulations for constructing the second formwork layer. This comparison makes it clear that using JAI elements can provide significant potential savings.

	Unit	Single-layer elevator shaft with JAI*	Two-layer elevator shaft without JAI
Basic data			
Clear shaft width	m	1.65	1.65
Clear shaft depth	m	1.75	1.75
Clear shaft height	m	14.90	14.90
Shaft wall thickness	m	0.30	0.30
Clear door opening width	m	1.14	1.14
Clear door opening height	m	2.20	2.20
Entrances	Pcs	5	5
Insulation layer thickness (for 2-layer shaft)	m	0	0.03
2nd layer: Wall thickness	m	0	0.20
Volume calculation			
Reinforced concrete for elevator shaft	m ³	21	21
Insulation for separating joints	m ²	0	108
Reinforced concrete for 2nd layer	m ³	0	24
Cost calculation (net)			
Elevator shaft	m ³	€14,700.00	€14,700.00
Allowance for door openings	Pcs	€500.00	€500.00
Allowance for shaft smoke extraction	Pcs	€50.00	€50.00
JTA-W 40/22 anchor channels	Pcs	€1,160.00	€1160.00
Scaffolding sleeve	Pcs	€24.00	€24.00
WLL 20 kN lifting eye	Pcs	€130.00	€130.00
JAI-JORDAHL isolating element	Pcs	€6,000.00	€0.00
Insulation for separating joints	m ²	€0.00	€864.00
2nd layer	m ³	€0.00	€16,800.00
Allowance for door openings	Pcs	€0.00	€500.00
"Allowance for circumferential joint construction on the entrances (5 pcs)"	Pcs	€0.00	€2,250.00
Allowance for incidental expenses (planning/statics)	flat rate	€0.00	€1,000.00
Total for elevator shaft (net)		€22,564.00	€37,978.00
Difference (net)		€15,414.00	

*assuming values derived from practice from 2020

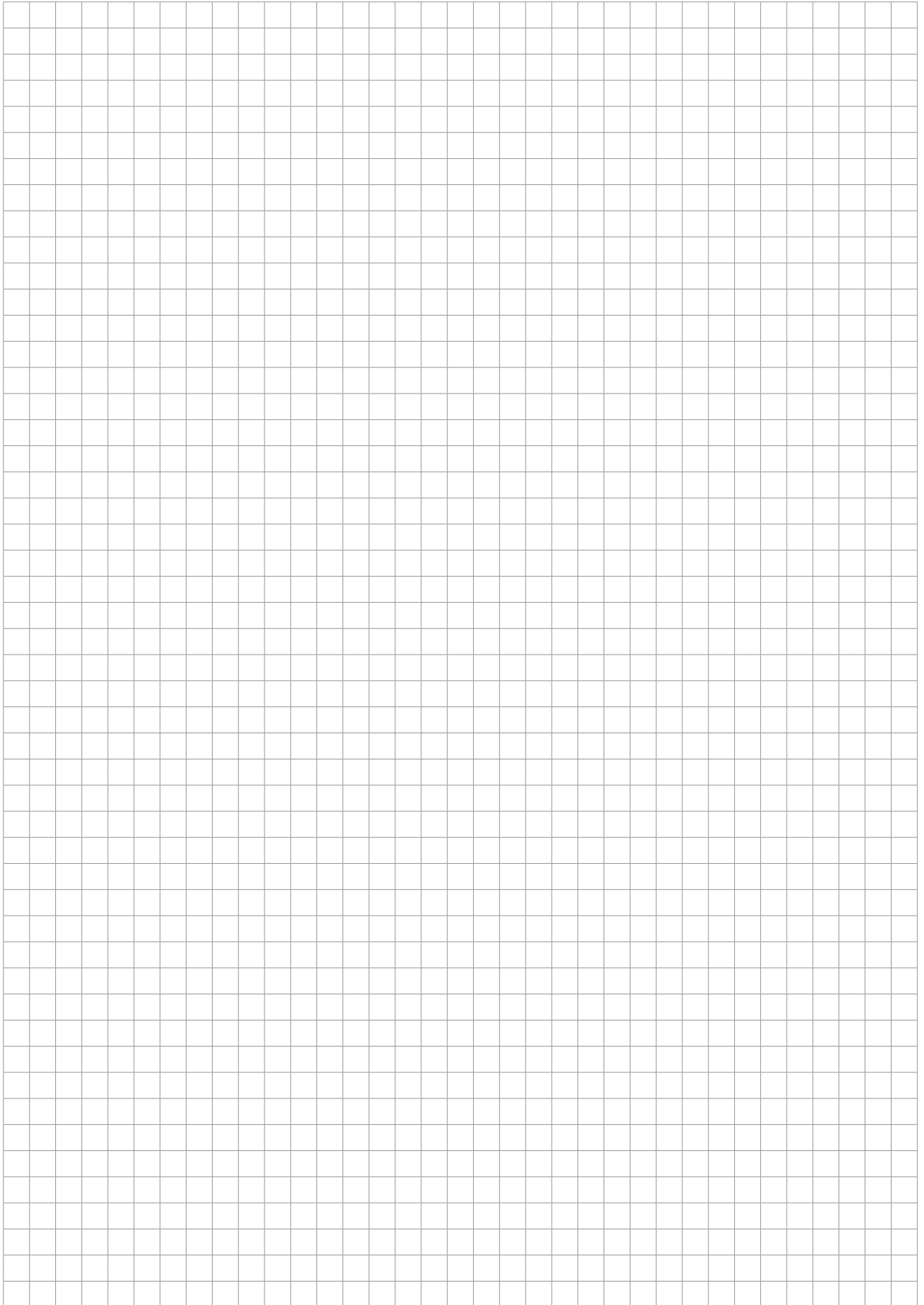

Our synergy concept for your benefit

With us, you benefit from the collective experience of three established manufacturers, who combine products and expertise in a comprehensive range. That is the PohlCon synergy concept.



Full-service consulting

Our extensive network of consultants is available to answer all your questions about our products on site. From planning to use, you can enjoy personal support from our qualified employees.



Digital solutions

Our digital solutions provide targeted support in planning with our products. From tender texts to CAD details and BIM data, right through to modern software solutions, we offer customized support for your planning process.



7 fields of application

We think in terms of holistic solutions. This is why we have combined our products into seven fields of application, where you can benefit from their synergy and the overall PohlCon product portfolio.

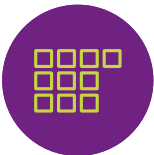

10 product categories

In order to find the right product in our extensive range even faster, we have divided our products into ten product categories. This way you can navigate unerringly between our products.



Individual solutions

No series product on the market is suitable for your project? We realize unique construction projects and exceptional challenges with the many years of expertise of the three manufacturing brands.



Content subject to technical change without notice. Errors and omissions excepted. This document may not be reprinted or electronically reproduced without our prior written permission. This document supersedes all previous documentation; its publication renders all previous documentation invalid.

PohlCon GmbH

Nobelstraße 51
12057 Berlin, Germany

T +49 (0) 30 68283-04
F +49 (0) 30 68283-383

www.pohlcon.com